

2Gb (8Mx8Banksx32) Low Power DDR4 SDRAM

Descriptions

H2AB02G32D6B uses the double data rate architecture on the Command/Address (CA) bus to reduce the number of input pins in the system. Each command uses one clock cycle, during which command information is transferred on both the positive and negative edge of the clock. To achieve high-speed operation, our H2AB02G32D6B SDRAM adopt 16n-prefetch interface designed to transfer two data per clock cycle at the I/O pins. A single read or write access for the H2AB02G32D6B effectively consists of a single 8n-bit wide, one clock cycle data transfer at the internal SDRAM core and eight corresponding n-bit wide, one-half-clock-cycle data transfer at the I/O pins. Read and write accesses to the H2AB02G32D6B are burst oriented; accesses start at a selected location and continue for a programmed number of locations in a programmed sequence.

For H2AB02G32D6B devices, accesses begin with the registration of an Active command, which is then followed by a Read or Write command. The address and BA bits registered coincident with the Active command are used to select the row and the Bank to be accessed. The address bits registered coincident with the Read or Write command are used to select the Bank and the starting column location for the burst access.

Features

- Frequency to 2133MHz (data rate: 4266Mbps/pin)
- 16n prefetch DDR architecture
- 8 internal banks per channel for concurrent operation
- Data width: x32
- Bidirectional/differential data strobe per byte lane
- Programmable READ and WRITE latencies (RL/WL)
- Programmable Burst Lengths: 16,32
- Interface: LVSTL_11
- Burst type: Sequential
- Programmable Driver strength
- Support write mask and data bus inversion (DBI)
- On-die termination (ODT)
- Auto Refresh and Self Refresh Modes
- Input clock stop and frequency change
- Write leveling support
- DQ-DQS training
- Target Row Refresh Mode
- CA training support
- FBGA “green” package - 200-ball FBGA
- Operating temperature range :
Commercial : 0°C to 85°C
- Double data rate architecture on the DQ pins
- VDD1/VDD2/VDDQ= 1.8V/1.1V/1.1V

Ordering Information

Part No	Organization	Max. Data Rate	Package	Grade
H2AB02G32D6BKAAC	64M X 32	LP DDR4-3200	200Ball BGA,10x14.5mm	Commercial
H2AB02G32D6BPAAC	64M X 32	LP DDR4-3733		Commercial
H2AB02G32D6BQAAC	64M X 32	LP DDR4-4266		Commercial

Pin Assignment

[Top View]

	1	2	3	4	5	6	7	8	9	10	11	12
A	DNU	DNU	VSS	VDD2	ZQ0			NC	VDD2	VSS	DNU	DNU
B	DNU	DQ0_A	VDDQ	DQ7_A	VDDQ			VDDQ	DQ15_A	VDDQ	DQ8_A	DNU
C	VSS	DQ1_A	DM10_A	DQ6_A	VSS			VSS	DQ14_A	DM11_A	DQ9_A	VSS
D	VDDQ	VSS	DQS0_t_A	VSS	VDDQ			VDDQ	VSS	DQS1_t_A	VSS	VDDQ
E	VSS	DQ2_A	DQS0_c_A	DQ5_A	VSS			VSS	DQ13_A	DQS1_c_A	DQ10_A	VSS
F	VDD1	DQ3_A	VDDQ	DQ4_A	VDD2			VDD2	DQ12_A	VDDQ	DQ11_A	VDD1
G	VSS	ODT_CA_A	VSS	VDD1	VSS			VSS	VDD1	VSS	NC	VSS
H	VDD2	CA0_A	NC	CS0_A	VDD2			VDD2	CA2_A	CA3_A	CA4_A	VDD2
J	VSS	CA1_A	VSS	CKE0_A	NC			CK_t_A	CK_c_A	VSS	CA5_A	VSS
K	VDD2	VSS	VDD2	VSS	NC			NC	VSS	VDD2	VSS	VDD2
L												
M												
N	VDD2	VSS	VDD2	VSS	NC			NC	VSS	VDD2	VSS	VDD2
P	VSS	CA1_B	VSS	CKE0_B	NC			CK_t_B	CK_c_B	VSS	CA5_B	VSS
R	VDD2	CA0_B	NC	CS0_B	VDD2			VDD2	CA2_B	CA3_B	CA4_B	VDD2
T	VSS	ODT_CA_B	VSS	VDD1	VSS			VSS	VDD1	VSS	RESET_n	VSS
U	VDD1	DQ3_B	VDDQ	DQ4_B	VDD2			VDD2	DQ12_B	VDDQ	DQ11_B	VDD1
V	VSS	DQ2_B	DQS0_c_B	DQ5_B	VSS			VSS	DQ13_B	DQS1_c_B	DQ10_B	VSS
W	VDDQ	VSS	DQS0_t_B	VSS	VDDQ			VDDQ	VSS	DQS1_t_B	VSS	VDDQ
Y	VSS	DQ1_B	DM10_B	DQ6_B	VSS			VSS	DQ14_B	DM11_B	DQ9_B	VSS
AA	DNU	DQ0_B	VDDQ	DQ7_B	VDDQ			VDDQ	DQ15_B	VDDQ	DQ8_B	DNU
AB	DNU	DNU	VSS	VDD2	VSS			VSS	VDD2	VSS	DNU	DNU

200-Ball FBGA

Pin Description (Simplified)

Symbol	Type	Description
CK_t_A, CK_c_A, CK_t_B, CK_c_B	Input	Clock: CK_t and CK_c are differential clock inputs. All address, command and control input signals are sampled on positive edge of CK_t and the negative edge of CK_c. AC timings for CA parameters are referenced to clock. Each channel (A, B) has its own clock pair.
CKE_A, CKE_B	Input	Clock enable: CKE HIGH activates and CKE LOW deactivates the internal clock circuits, input buffers, and output drivers. Power-saving modes are entered and exited via CKE transitions. Each channel (A & B) has its own CKE signal.
CS_A, CS_B	Input	Chip select: CS is part of the command code. Each channel (A & B) has its own CS signal
CA[5:0]_A, CA[5:0]_B	Input	Command/address inputs: Provide the command and address inputs according to the command truth table. Each channel (A, B) has its own CA signals.
ODT_CA_A, ODT_CA_B	Input	CA ODT Control: The ODT_CA pin is used in conjunction with the Mode Register to turn on/off the On-Die-Termination for CA pins.
DQ[15:0]_A, DQ[15:0]_B	I/O	Data input/output: Bidirectional data bus.
DQS[1:0]_t_A, DQS[1:0]_c_A, DQS[1:0]_t_B, DQS[1:0]_c_B	I/O	Data strobe: DQS_t and DQS_c are bi-directional differential output clock signals used to strobe data during a READ or WRITE. The data strobe is generated by the DRAM for a READ and is edge-aligned with data. The data strobe is generated by the SoC memory controller for a WRITE and is trained to precede data. Each byte of data has a data strobe signal pair. Each channel (A, B) has its own DQS_t and DQS_c strobes.
DMI[1:0]_A, DMI[1:0]_B	I/O	Data Mask/Data Bus Inversion: DMI is a dual use bi-directional signal used to indicate data to be masked, and data which is inverted on the bus. For data bus inversion (DBI), the DMI signal is driven HIGH when the data on the data bus is inverted, or driven LOW when the data is in its normal state. DBI can be disabled via a mode register setting. For data mask, the DMI signal is used in combination with the data lines to indicate data to be masked in a MASK WRITE command (see the Data Mask (DM) and Data Bus Inversion (DBI) sections for details). The data mask function can be disabled via a mode register setting. Each byte of data has a DMI signal. Each channel has its own DMI signals.
ZQ0	Reference	ZQ Calibration Reference: Used to calibrate the output drive strength and the termination resistance. The ZQ0 pin shall be connected to VDDQ through a 240Ω ± 1% resistor.
VDDQ, VDD1, VDD2	Supply	Power supplies: Isolated on the die for improved noise immunity.
VSS, VSSQ	Supply	Ground Reference: Power supply ground reference.
RESET_n	Input	RESET: When asserted LOW, the RESET pin resets both channels of the die.
DNU		Do not use: Must be grounded or left floating.
NC		No connect: Not internally connected.

Absolute Maximum Rating

Symbol	Item	Rating	Units
V _{IN} , V _{OUT}	Voltage on any ball relative to VSS	-0.4 ~ 1.5	V
V _{DD1}	VDD1 supply voltage relative to VSS	-0.4 ~ 2.1	V
V _{DD2}	VDD2 supply voltage relative to VSS	-0.4 ~ 1.5	V
V _{DDQ}	VDDQ supply voltage relative to VSS	-0.4 ~ 1.5	V
T _{STG}	Storage Temperature (plastic)	-55 ~ 125	°C

Note 1: For information about relationships between power supplies, see the Voltage Ramp and Device Initialization section.

Note 2: Storage temperature is the case surface temperature on the center/top side of the device.
For measurement conditions, refer to the JESD51-2 standard.

Input / Output Capacitance

Symbol	Parameter	Min.	Max.	Units
C _{CK}	Input capacitance, CK _t and CK _c	0.5	0.9	pF
C _{DCK}	Input capacitance delta, CK _t and CK _c	0	0.09	pF
C _I	I Input capacitance, all other input-only pins	0.5	0.9	pF
C _{DI}	Input capacitance delta, all other input-only pins	-0.1	0.1	pF
C _{IO}	Input/output capacitance, DQ, DMI, DQS _t , DQS _c	0.7	1.3	pF
C _{DDQS}	Input/output capacitance delta, DQS _t , DQS _c	0	0.1	pF
C _{DIO}	Input/output capacitance delta, DQ, DMI	-0.1	0.1	pF
C _{ZQ}	Input/output capacitance, ZQ pin	0	5.0	pF

Note 1: This parameter is not subject to production testing. It is verified by design and characterization.

Note 2: Absolute value of CCK_t – CCK_c

Note 3: C_I applies to CS, CKE and CA[5:0].

Note 4: C_{DI} = C_I – 0.5 × (CCK_t + CCK_c); it does not apply to CKE.

Note 5: DMI loading matches DQ and DQS.

Note 6: Absolute value of CDQS_t and CDQS_c.

Note 7: This parameter applies to LPDDR4 die only (does not include package capacitance).

Recommended DC Operating Conditions

Symbol	Parameter	Min.	Typ.	Max.	Units
V _{DD1}	Core Supply voltage 1	1.70	1.80	1.95	V
V _{DD2}	Core Supply voltage 2	1.06	1.10	1.17	V
V _{DDQ}	I/O buffer power	1.06	1.10	1.17	V

Notes: 1. VDD1 uses significantly less power than VDD2.

Notes: 2. The voltage range is for DC voltage only. DC voltage is the voltage supplied at the DRAM and is inclusive of all noise up to 20 MHz at the DRAM package ball.

Notes: 3. The voltage noise tolerance from DC to 20 MHz exceeding a peak-to-peak tolerance of 45mV at the DRAM ball is not included in the TdIVW.

DC Characteristics

(IDD Specifications; VDD2, VDDQ = 1.06–1.17V; VDD1 = 1.70–1.95V)

Symbol		Supply	Speed Grade		Unit
			3733	4266	
IDD0	IDD01	VDD1	12.3	12.3	mA
	IDD02	VDD2	55	55	
	IDD0Q	VDDQ	0.5	0.5	
IDD2P	IDD2P1	VDD1	0.4	0.4	mA
	IDD2P2	VDD2	5	5	
	IDD2PQ	VDDQ	0.5	0.5	
IDD2PS	IDD2PS1	VDD1	0.4	0.4	mA
	IDD2PS2	VDD2	5	5	
	IDD2PSQ	VDDQ	0.5	0.5	
IDD2N	IDD2N1	VDD1	0.35	0.4	mA
	IDD2N2	VDD2	40	40	
	IDD2NQ	VDDQ	0.5	0.5	
IDD2NS	IDD2NS1	VDD1	0.4	0.4	mA
	IDD2NS2	VDD2	27	27	
	IDD2NSQ	VDDQ	0.5	0.5	
IDD3P	IDD3P1	VDD1	2.1	2.1	mA
	IDD3P2	VDD2	6.5	6.5	
	IDD3PQ	VDDQ	0.5	0.5	
IDD3PS	IDD3PS1	VDD1	2.1	2.1	mA
	IDD3PS2	VDD2	6.5	6.5	
	IDD3PSQ	VDDQ	0.5	0.5	
IDD3N	IDD3N1	VDD1	2.2	2.2	mA
	IDD3N2	VDD2	41	41	
	IDD3NQ	VDDQ	0.5	0.5	
IDD3NS	IDD3NS1	VDD1	2.2	2.2	mA
	IDD3NS2	VDD2	31	31	
	IDD3NSQ	VDDQ	0.5	0.5	
IDD4R	IDD4R1	VDD1	4.5	4.5	mA
	IDD4R2	VDD2	345	390	
	IDD4RQ	VDDQ	115	125	
IDD4W	IDD4W1	VDD1	3.5	3.5	mA
	IDD4W2	VDD2	320	345	
	IDD4WQ	VDDQ	0.5	0.5	

DC Characteristics(Continued)

(IDD Specifications; VDD2, VDDQ= 1.06~1.17V, VDD1 = 1.70~1.95V)

Symbol		Supply	Speed		Unit
			3733	4266	
IDD5	IDD51	VDD1	30	30	mA
	IDD52	VDD2	77	80	
	IDD5Q	VDDQ	0.5	0.5	
IDD5AB	IDD5AB1	VDD1	1.4	1.4	mA
	IDD5AB2	VDD2	44.5	46.5	
	IDD5ABQ	VDDQ	0.5	0.5	
IDD5PB	IDD5PB1	VDD1	3.2	3.2	mA
	IDD5PB2	VDD2	46.5	48.5	
	IDD5PBQ	VDDQ	0.5	0.5	

Notes: 1. ODT disabled: MR11 OP[2:0] = 000b

Notes: 2. Guaranteed by design with output load = 5pF and RON = 40Ω.

Notes: 3. For all IDD measurements, VIHCKE = 0.8 x VDD2, VILCKE = 0.2 x VDD2.

IDD6 Partial Array Self-refresh current; VDD2,VDDQ= 1.06~1.17V, VDD1 = 1.70~1.95V

PASR	Supply	Temp.		Unit
		85°C	95°C	
Full Array	VDD1	0.23	2.4	mA
	VDD2	0.77	7	
	VDDQ	0.01	0.5	

Notes: 1. IDD values reflect dual-channel operation with the same pattern for each channel.

Notes: 2. IDD6 typical value of 85°C. IDD6 85°C is typical of the distribution of the arithmetic mean.

Input Levels for ODT_CA

Parameter	Symbol	Min.	Max.	Unit
ODT input HIGH level	VIHODT	0.75 x VDD2	VDD2 + 0.2	V
ODT input LOW level	VILODT	-0.2	0.25 x VDD2	V

Single-Ended Output Slew Rate

Parameter	Symbol	Value		Unit
		Min.	Max.	
Single-ended output slew rate ($V_{OH} = V_{DDQ} \times 0.5$)	SRQse	3.5	9.0	V/ns
Output slew rate matching ratio (rise to fall)	-	0.8	1.2	-

Note 1: SR = Slew rate; Q = Query output; se = Single-ended signal.

Note 2: Measured with output reference load.

Note 3: The ratio of pull-up to pull-down slew rate is specified for the same temperature and voltage, over the entire temperature and voltage range. For a given output, it represents the maximum difference between pull-up and pull-down drivers due to process variation.

Note 4: The output slew rate for falling and rising edges is defined and measured between $V_{OL}(AC) = 0.2 \times V_{OH}(DC)$ and $V_{OH}(AC) = 0.8 \times V_{OH}(DC)$.

Note 5: Slew rates are measured under average SSO conditions with 50% of the DQ signals per data byte switching.

Differential Output Slew Rate

Parameter	Symbol	Value		Unit
		Min.	Max.	
Differential output slew rate ($V_{OH} = V_{DDQ} \times 0.5$)	SRQdiff	7	18	V/ns

Note 1: SR = Slew rate; Q = Query output; se = Differential signal

Note 2: Measured with output reference load.

Note 3: The output slew rate for falling and rising edges is defined and measured between $V_{OL}(AC) = -0.8 \times V_{OH}(DC)$ and $V_{OH}(AC) = 0.8 \times V_{OH}(DC)$.

Note 4: Slew rates are measured under average SSO conditions with 50% of the DQ signals per data byte Switching.

Block Diagram

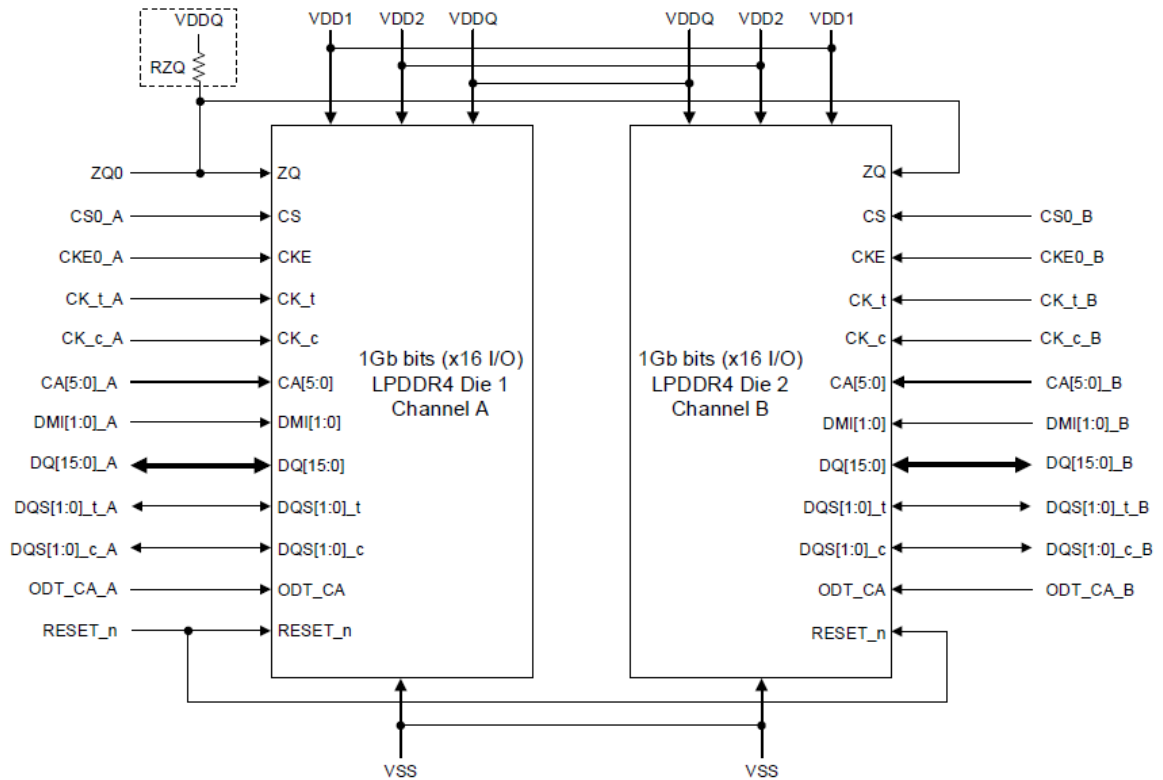

Note: In dash line block RZQ and VDDQ are external component.

AC Characteristics

($V_{DD2}, V_{DDQ}, V_{DDCA}=1.06\sim1.17V, V_{DD1}=1.70\sim1.95V$)

Symbol	Parameter	Min/Max	Data Rate		Unit
			3733	4266	
Clock Timing					
tCK(avg)	Average clock period	Min	535	468	ps
		Max	100	100	ns
tCH(avg)	Average HIGH pulse width	Min	0.46	0.46	tCK(avg)
		Max	0.54	0.54	tCK(avg)
tCL(avg)	Average LOW pulse width	Min	0.46	0.46	tCK(avg)
		Max	0.54	0.54	tCK(avg)
tCK(abs)	Absolute clock period	Min	tCK(avg) MIN + tJIT(per) MIN		ps
tCH(abs)	Absolute clock HIGH pulse width	Min	0.43	0.43	tCK(avg)
		Max	0.57	0.57	tCK(avg)
tCL(abs)	Absolute clock LOW pulse width	Min	0.43	0.43	tCK(avg)
		Max	0.57	0.57	tCK(avg)
tJIT(per), allowed	Clock period jitter	Min	-34	-30	ps
		Max	34	30	ps
tJIT(cc), allowed	Maximum clock jitter between two consecutive clock cycles (with clock period jitter)	Max	68	60	ps

AC Characteristics (Continued)
 $(V_{DD2}, V_{DDQ}, V_{DDCA}=1.06\sim 1.17V, V_{DD1}=1.70\sim 1.95V)$

Symbol	Parameter	Min/ Max	Data Rate		Unit
			3733	4266	
ZQ Calibration Parameters					
tZQCAL	ZQCAL START to ZQCAL LATCH command interval	Min	1		us
tZQLAT	ZQCAL LATCH to next valid command interval	Min	MAX(30ns, 8nCK)		ns
tZQRESET	ZQCAL RESET to next valid command interval	Min	MAX(50ns, 3nCK)		ns
READ Parameters					
tDQSCK	DQS output access time from CK	Min	1500		ps
		Max	3500		ps
tDQSCK_VOLT	DQS output access time from CK_t/CK_c – voltage variation	Max	7		ps/mV
tDQSCK_TEMP	DQS output access time from CK_t/CK_c – temperature variation	Max	4		ps/°C
tDQSCK_rank2rank	CK to DQS rank to rank variation	Max	1.0		ns
tDQSQ	DQS-DQ skew	Max	0.18		UI
tQH	DQ output hold time total from DQS_t, DQS_c	Min	Min (tQSH, tQSL)		ps
tRPRE	READ preamble	Min	1.8		tCK(avg)
tRPST	0.5 tck READ postamble	Min	0.4		tCK(avg)
tLZ(DQS)	DQS Low-Z from clock	Min	$(RL \times tCK) + tDQSCK(\text{Min}) - (tRPRE(\text{Max}) \times tCK) - 200\text{ps}$		ps
tLZ(DQ)	DQ Low-Z from clock	Min	$(RL \times tCK) + tDQSCK(\text{Min}) - 200\text{ps}$		ps
tHZ(DQS)	DQS High-Z from clock	Min	$(RL \times tCK) + tDQSCK(\text{Max}) + (BL/2 \times tCK) + (tRPST(\text{Max}) \times tCK) - 100\text{ps}$		ps
tHZ(DQ)	DQ High-Z from clock	Max	$t(RL \times tCK) + tDQSCK(\text{Max}) + tDQSQ(\text{Max}) + (BL/2 \times tCK) - 100\text{ps}$		ps
tQW_total	Data output valid window time total, per pin	Min	0.70	0.70	UI
tDQSQ_DBI	DQS_t, DQS_c to DQ skew total, per group, per access	Max	0.18		UI
tQH_DBI	DQ output hold time total from DQS_t, DQS_c	Min	MIN(tQSH_DBI, tQSL_DBI)		ps
tQW_total_DBI	Data output valid window time total, per pin	Min	0.70	0.70	UI
tQSL	DQS_t, DQS_c differential output LOW time	Min	tCL(abs) – 0.05		tCK(avg)
tQSH	DQS_t, DQS_c differential output HIGH time	Min	tCH(abs) – 0.05		tCK(avg)
tQSL-DBI	DQS_t, DQS_c differential output LOW time	Min	tCL(abs) – 0.045		tCK(avg)
tQSH-DBI	DQS_t, DQS_c differential output HIGH time	Min	tCH(abs) – 0.045		tCK(avg)

AC Characteristics (Continued)
 $(V_{DD2}, V_{DDQ}, V_{DDCA}=1.06\sim 1.17V, V_{DD1}=1.70\sim 1.95V)$

Symbol	Parameter	Min/ Max	Data Rate		Unit
			3733	4266	
CKE Input Parameters					
t _{CKE}	CKE minimum pulse width(HIGH and LOW pulse width)	Min	Max(7.5ns, 4nCK)		ns
t _{CMDCKE}	Delay from valid command to CKE input LOW	Min	Max(1.75ns, 3nCK)		ns
t _{CKELCK}	Valid clock requirement after CKE input LOW	Min	MAX(5ns, 5nCK)		ns
t _{CSCKE}	Valid CS requirement before CKE input LOW	Min	1.75		ns
t _{CKELCS}	Valid CS requirement after CKE input LOW	Min	MAX(5ns, 5nCK)		ns
t _{CKCKEH}	Valid Clock requirement before CKE Input HIGH	Min	MAX(1.75ns, 3nCK)		ns
t _{XP}	Exit power-down to next valid command delay	Min	MAX(7.5ns, 5nCK)		ns
t _{CSCKEH}	Valid CS requirement before CKE input HIGH	Min	1.75		ns
t _{CKEHCS}	Valid CS requirement after CKE input HIGH	Min	MAX(7.5ns, 5nCK)		ns
t _{MRWCKEL}	Valid clock and CS requirement after CKE input LOW after MRW command	Min	MAX(14ns, 10nCK)		ns
t _{ZQCKE}	Valid clock and CS requirement after CKE input LOW after ZQ calibration start command	Min	MAX(1.75ns, 3nCK)		ns
Command Address Input Parameters					
t _{clVW}	Command/address valid window	Min	0.3		t _{CK} (avg)
t _{clPW}	Address and control input pulse width	Min	0.6		t _{CK} (avg)
Boot Parameters (10–55 MHz)					
t _{CKb}	Clock cycle time	Max	-		ns
		Min	18		ns
t _{DQSCKb}	DQS output data access time from CK	Min	TBD		ns
		Max	TBD		ns
t _{DQSQb}	Data strobe edge to output data edge	Max	TBD		ns
Mode Register Parameters					
t _{MRW}	MODE REGISTER WRITE command period	Min	MAX(10ns, 10nCK)		ns
t _{MRD}	MODE REGISTER SET command delay	Min	MAX(14ns, 10nCK)		ns
t _{MRR}	MODE REGISTER READ command period	Min	8		t _{CK} (avg)
t _{MRRl}	Additional time after t _{XP} has expired until MRR command may be issued	Min	t _{RCD} (min) + 3nCK		ns
t _{SDO}	Delay from MRW command to DQS driven out	Max	MAX(12nCK, 20ns)		ns

AC Characteristics (Continued)
 $(V_{DD2}, V_{DDQ}, V_{DDCA}=1.06\sim 1.17V, V_{DD1}=1.70\sim 1.95V)$

Symbol	Parameter	Min/Max	Data Rate		Unit
			3733	4266	
Core Parameters					
RL-A	READ latency (DBI disabled)	Min	32	36	tCK(avg)
RL-B	READ latency (DBI enabled)	Min	36	40	tCK(avg)
WL-A	WRITE latency (Set A)	Min	16	18	tCK(avg)
WL-B	WRITE latency (Set B)	Min	30	34	tCK(avg)
tRC	ACTIVATE-to-ACTIVATE command period	Min	tRAS + tRPab (with all-bank precharge) tRAS + tRPpb (with per-bank precharge)		ns
tSR	Minimum self refresh time (entry to exit)	Min	MAX(15ns, 3nCK)		ns
tXSR	Self refresh exit to next valid command delay	Min	MAX(tRFCab + 7.5ns, 2nCK)		ns
tCCD	CAS-to-CAS delay	Min	8		tCK(avg)
tCCDMW	CAS-to-CAS delay masked write	Min	32		tCK(avg)
tRTP	Internal READ to PRECHARGE command delay	Min	Max (7.5ns, 8nCK)		ns
tRCD	RAS-to-CAS delay	Min	Max (18ns, 4nCK)		ns
tRPpb	Row precharge time (single bank)	Min	Max (18ns, 4nCK)		ns
tRPpab	Row precharge time (all banks)	Min	Max (21ns, 4nCK)		ns
tRAS	Row active time	Min	Max (42ns, 3nCK)		ns
		Max	MIN(9 × tREFI × Refresh Rate, 70.2)		us
tWR	WRITE recovery time	Min	Max (18ns, 6nCK)		ns
tWTR	WRITE-to- READ command delay	Min	Max (10ns, 8nCK)		ns
tRRD	Active bank A to active bank B	Min	Max (10ns, 4nCK)	Max (7.5ns, 4nCK)	ns
tPPD	Precharge-to-precharge delay	Min	4		tCK(avg)
tFAW	Four-bank activate window	Min	40	30	ns
tESCKE	Delay from SRE command to CKE input LOW	Min	MAX(1.75ns, 3nCK)		-

AC Characteristics (Continued)

(V_{DD2} , V_{DDQ} , V_{DDCA} = 1.06~1.17V, V_{DD1} = 1.70~1.95V)

Symbol	Parameter	Min/Max	Data Rate		Unit
			3733	4266	
CA Bus Training Parameters					
tCKELCK	Valid clock requirement after CKE Input LOW	Min	MAX(5ns, 5nCK)		tCK
tDStrain	Data setup for VREF training mode	Min	2		ns
tDHtrain	Data hold for VREF training mode	Min	2		ns
tADR	Asynchronous data ready	Max	20		ns
tCACD	CA BUS TRAINING command- to-command delay	Min	RU(tADR/tCK)		tCK
tDQSCKE	Valid strobe requirement before CKE LOW	Max	10		ns
tCAENT	First CA BUS TRAINING command following CKE LOW	Min	250		ns
tVREFca_LONG	VREF step time – multiple steps	Max	250		ns
tVREFca_SHORT	VREF step time – one step	Max	80		ns
tCKPRECS	Valid clock requirement before CS HIGH	Min	2tCK + tXP		-
tCKPSTCS	Valid clock requirement after CS HIGH	Min	MAX(7.5ns, 5nCK)		-
tCS_VREF	Minimum delay from CS to DQS toggle in command bus training	Min	2		tCK
tCKEHDQS	Minimum delay from CKE HIGH to strobe High-Z	Min	10		ns
tMRZ	CA bus training CKE HIGH to DQ tri-state	Min	1.5		ns
tCKELODton	ODT turn-on latency from CKE	Min	20		ns
tCKEHODtoff	ODT turn-off latency from CKE	Min	20		ns
tXCBT_Short	Exit command bus training mode to next valid command delay	Min	MAX(200ns, 5nCK)		-
tXCBT_Middle		Min	MAX(200ns, 5nCK)		-
tXCBT_Long		Min	MAX(250ns, 5nCK)		-

Write Voltage and Timing					
TdIVW_total	Rx timing window total at VdIVW voltage levels	Max	0.25	0.25	UI
TdIVW_1-bit	Rx timing window 1-bit toggle (at VdIVW voltage levels)	Max	TBD		UI
TdIPW	DQ and DMI input pulse width (at VCENT_DQ)	Min	0.45		UI
tDQS2DQ	DQ-to-DQS offset	Min	200		ps
		Max	800		
tDQDQ	DQ-to-DQ offset	Max	30		ps
tDQS2DQ_tem	DQ-to-DQS offset temperature variation	Max	0.6		ps/°C
tDQS2DQ_volt	DQ-to-DQS offset voltage variation	Max	33		ps/50mV
tDQSS	WRITE command to first DQS transition	Min	0.75		tCK(avg)
		Max	1.25		
tDQSH	DQS input HIGH-level width	-	0.4		tCK(avg)
tDQSL	DQS input LOW-level width	Min	0.4		tCK(avg)
tDSS	DQS falling edge to CK setup time	Min	0.2		tCK(avg)
tDSH	DQS falling edge from CK hold time	Min	0.2		tCK(avg)
tWPST	Write postamble	Min	0.4 (or 1.4 if extra postamble is programmed in MR)		tCK(avg)
tWPRE	Write preamble	Min	1.8		tCK(avg)
Temperature Derating Parameters					
tDQSCKd	DQS output access time from CK_t/CK_c (derated)	Max	3600		ps
tRCDd	RAS-to-CAS delay (derated)	Min	tRCD + 1.875		ns
tRCd	ACTIVATE-to-ACTIVATE command period (same bank, derated)	Min	tRC + 3.75		ns
tRASd	Row active time (derated)	Min	tRAS + 1.875		ns
tRPd	Row precharge time (derated)	Min	tRP + 1.875		ns
tRRD	Active bank A to active bank B (derated)	Min	tRRD + 1.875		ns

Simplified State Diagram

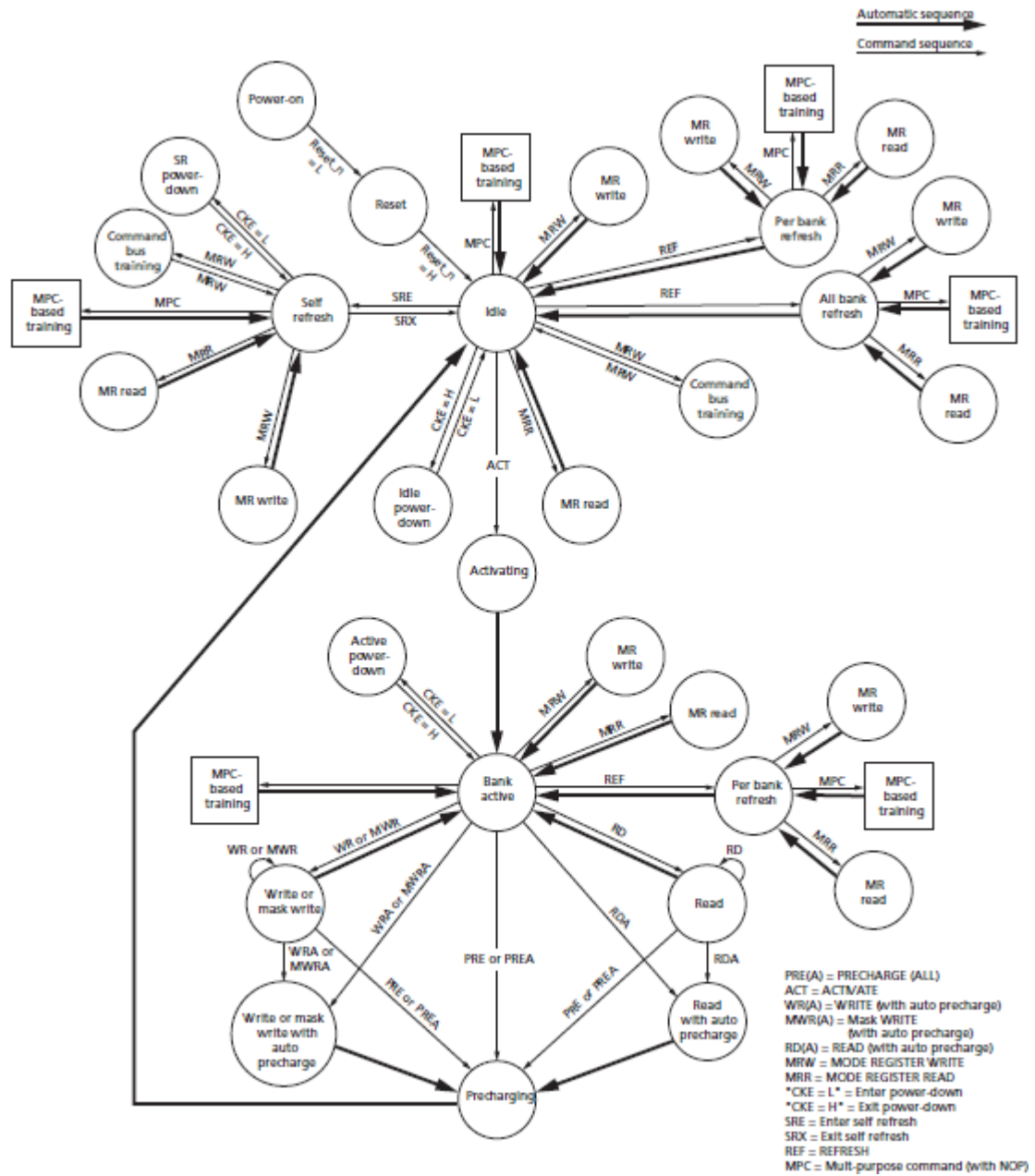

Command Truth Table

Commands are transmitted to the device across a six-lane interface and use CK, CKE, and CS to control the capture of transmitted data.

SDRAM Command	SDR Command Pins	SDR CA Pins (6)						CK_t edge	Notes
	CS	CA0	CA1	CA2	CA3	CA4	CA5		
Deselect (DES)	L	X						R1	1,2
Multi-Purpose Command (MPC)	H	L	L	L	L	L	OP6	R1	1,9
	L	OP0	OP1	OP2	OP3	OP4	OP5	R2	
Precharge (PRE) (Per Bank, All Bank)	H	L	L	L	L	H	AB	R1	1,2,3,4
	L	BA0	BA1	BA2	V	V	V	R2	
Refresh (REF) (Per Bank, All Bank)	H	L	L	L	H	L	AB	R1	1,2,3,4
	L	BA0	BA1	BA2	V	V	V	R2	
Self Refresh Entry (SRE)	H	L	L	L	H	H	V	R1	1,2
	L	V						R2	
Write -1 (WR-1)	H	L	L	H	L	L	BL	R1	1,2,3,6,7,9
	L	BA0	BA1	BA2	V	C9	AP	R2	
Self Refresh Exit (SRX)	H	L	L	H	L	H	V	R1	1,2
	L	V						R2	
Mask Write -1 (MWR-1)	H	L	L	H	H	L	L	R1	1,2,3,5,6,9
	L	BA0	BA1	BA2	V	C9	AP	R2	
RFU	H	L	L	H	H	H	V	R1	1,2
	L	V						R2	
Read -1 (RD-1)	H	L	H	L	L	L	BL	R1	1,2,3,6,7,9
	L	BA0	BA1	BA2	V	C9	AP	R2	
CAS-2 (Write-2, Mask Write -2, Read-2, MRR-2, MPC)	H	L	H	L	L	H	C8	R1	1,8,9
	L	C2	C3	C4	C5	C6	C7	R2	
RFU	H	L	H	L	H	L	V	R1	1,2
	L	V						R2	
RFU	H	L	H	L	H	H	V	R1	1,2
	L	V						R2	
Mode Register Write-1 (MRW-1)	H	L	H	H	L	L	OP7	R1	1,11
	L	MA0	MA1	MA2	MA3	MA4	MA5	R2	
Mode Register Write-2 (MRW-2)	H	L	H	H	L	H	OP6	R1	1,11
	L	OP0	OP1	OP2	OP3	OP4	OP5	R2	
Mode Register Read-1 (MRR-1)	H	L	H	H	H	L	V	R1	1,2,12
	L	MA0	MA1	MA2	MA3	MA4	MA5	R2	
RFU	H	L	H	H	H	H	V	R1	1,2
	L	V						R2	
Activate-1 (ACT-1)	H	H	L	R12	R13	X	X	R1	1,2,3,10
	L	BA0	BA1	BA2	X	R10	R11	R2	
Activate-2 (ACT-2)	H	H	H	R6	R7	R8	R9	R1	1,10
	L	R0	R1	R2	R3	R4	R5	R2	

- Note 1:** All commands except for DESELECT are two clock cycles and are defined by the current state of CS and CA[5:0] at the rising edge of the clock. DESELECT command is one clock cycle and is not latched by the device.
- Note 2:** V = H or L (a defined logic level); X = "Don't Care," in which case CS, CK_t, CK_c, and CA[5:0] can be floated.
- Note 3:** Bank addresses BA[2:0] determine which bank is to be operated upon.
- Note 4:** AB HIGH during PRECHARGE or REFRESH commands indicate the command must be applied to all banks, and the bank addresses are "Don't Care."
- Note 5:** MASK WRITE-1 command only supports BL16. For MASK WRITE-1 commands, CA5 must be driven LOW on the first rising clock cycle (R1).
- Note 6:** AP HIGH during a WRITE-1, MASK WRITE-1, or READ-1 command indicates that an auto precharge will occur to the bank the command is operating on. AP LOW indicates that no auto precharge will occur and the bank will remain open upon completion of the command.
- Note 7:** When enabled in the mode register, BL HIGH during a WRITE-1, MASK-WRITE-1, or READ-1 command indicates the burst length should be set on-the-fly to BL = 32; BL LOW during one of these commands indicates the burst length should be set on-the-fly to BL = 16. If on-the-fly burst length is not enabled in the mode register, this bit should be driven to a valid level and is ignored by the device.
- Note 8:** For CAS-2 commands (WRITE-2, MASK WRITE-2, READ-2, MRR-2, or MPC (only write FIFO, read FIFO and read DQ calibration), C[1:0] are not transmitted on the CA [5:0] bus and are assumed to be zero. Note that for CAS-2 WRITE-2 or CAS-2 MASK WRITE-2 command, C[3:2] must be driven LOW.
- Note 9:** WRITE-1, MASK-WRITE-1, READ-1, MODE REGISTER READ-1, or MPC (only write FIFO, read FIFO, and read DQ calibration) command must be immediately followed by CAS-2 command consecutively without any other command in between. WRITE-1, MASK WRITE-1, READ-1, MRR-1, or MPC (only write FIFO, read FIFO, and read DQ calibration) command must be issued first before issuing CAS-2 command. MPC (only Start and Stop DQS Oscillator, Start and Latch ZQ Calibration) commands do not require CAS-2 command; they require two additional DES or NOP commands consecutively before issuing any other commands.
- Note 10:** The ACTIVATE-1 command must be followed by the ACTIVATE-2 command consecutively without any other command between them. The ACTIVATE-1 command must be issued prior to the ACTIVATE-2 command. When the ACTIVATE-1 command is issued, the ACTIVATE-2 command must be issued before issuing another ACTIVATE-1 command.
- Note 11:** The MRW-1 command must be followed by the MRW-2 command consecutively without any other command between them. The MRW-1 command must be issued prior to the MRW-2 command.
- Note 12:** The MRR-1 command must be followed by the CAS-2 command consecutively without any other commands between them. The MRR-1 command must be issued prior to the CAS-2 command.

IDD Measurement Conditions

Definition of Switching for CA Input Signals

CK_t edge	R1	R2	R3	R4	R5	R6	R7	R8
CKE	H	H	H	H	H	H	H	H
CS	L	L	L	L	L	L	L	L
CA0	H	L	L	L	L	H	H	H
CA1	H	H	H	L	L	L	L	H
CA2	H	L	L	L	L	H	H	H
CA3	H	H	H	L	L	L	L	H
CA4	H	L	L	L	L	H	H	H
CA5	H	H	H	L	L	L	L	H

Notes 1: LOW = $V_{IN} \leq V_{IL(DC) MAX}$, HIGH = $V_{IN} \geq V_{IH(DC) MIN}$, STABLE = Inputs are stable at a HIGH or LOW level

Notes 2: CS must always be driven LOW.

Notes 3: 50% of CA bus is changing between HIGH and LOW once per clock for the CA bus.

Notes 4: The pattern is used continuously during IDD measurement for IDD values that require switching on the CA bus.

CA Pattern for IDD4R for BL=16

Clock Cycle Number	CKE	CS	Command	CA0	CA1	CA2	CA3	CA4	CA5
N	HIGH	HIGH	Read-1	L	H	L	L	L	L
N+1	HIGH	LOW		L	H	L	L	L	L
N+2	HIGH	HIGH	CAS-2	L	H	L	L	H	L
N+3	HIGH	LOW		L	L	L	L	L	L
N+4	HIGH	LOW	DES	L	L	L	L	L	L
N+5	HIGH	LOW	DES	L	L	L	L	L	L
N+6	HIGH	LOW	DES	L	L	L	L	L	L
N+7	HIGH	LOW	DES	L	L	L	L	L	L
N+8	HIGH	HIGH	Read-1	L	H	L	L	L	L
N+9	HIGH	LOW		L	H	L	L	H	L
N+10	HIGH	HIGH	CAS-2	L	H	L	L	H	H
N+11	HIGH	LOW		H	H	H	H	H	H
N+12	HIGH	LOW	DES	L	L	L	L	L	L
N+13	HIGH	LOW	DES	L	L	L	L	L	L
N+14	HIGH	LOW	DES	L	L	L	L	L	L
N+15	HIGH	LOW	DES	L	L	L	L	L	L

Notes 1: BA[2:0] = 010; CA[9:4] = 000000 OR 111111; Burst order CA[3:2] = 00 or 11.

Notes 2: CA pins are kept LOW with DES CMD to reduce ODT current.

CA Pattern for IDD4W for BL=16

Clock Cycle Number	CKE	CS	Command	CA0	CA1	CA2	CA3	CA4	CA5
N	HIGH	HIGH	Write-1	L	L	H	L	L	L
N+1	HIGH	LOW		L	H	L	L	L	L
N+2	HIGH	HIGH	CAS-2	L	H	L	L	H	L
N+3	HIGH	LOW		L	L	L	L	L	L
N+4	HIGH	LOW	DES	L	L	L	L	L	L
N+5	HIGH	LOW	DES	L	L	L	L	L	L
N+6	HIGH	LOW	DES	L	L	L	L	L	L
N+7	HIGH	LOW	DES	L	L	L	L	L	L
N+8	HIGH	HIGH	Write-1	L	L	H	L	L	L
N+9	HIGH	LOW		L	H	L	L	H	L
N+10	HIGH	HIGH	CAS-2	L	H	L	L	H	H
N+11	HIGH	LOW		L	L	H	H	H	H
N+12	HIGH	LOW	DES	L	L	L	L	L	L
N+13	HIGH	LOW	DES	L	L	L	L	L	L
N+14	HIGH	LOW	DES	L	L	L	L	L	L
N+15	HIGH	LOW	DES	L	L	L	L	L	L

Notes 1: BA[2:0] = 010; CA[9:4] = 000000 or 111111

Notes 2: No burst ordering

Notes 3: CA pins are kept LOW with DES CMD to reduce ODT current

Data Pattern for IDD4W(DBI off) for BL=16

DBI Off Case										
	DQ7	DQ6	DQ5	DQ4	DQ3	DQ2	DQ1	DQ0	DBI	# of 1s
BL0	1	1	1	1	1	1	1	1	0	8
BL1	1	1	1	1	0	0	0	0	0	4
BL2	0	0	0	0	0	0	0	0	0	0
BL3	0	0	0	0	1	1	1	1	0	4
BL4	0	0	0	0	0	0	1	1	0	2
BL5	0	0	0	0	1	1	1	1	0	4
BL6	1	1	1	1	1	1	0	0	0	6
BL7	1	1	1	1	0	0	0	0	0	4
BL8	1	1	1	1	1	1	1	1	0	8
BL9	1	1	1	1	0	0	0	0	0	4
BL10	0	0	0	0	0	0	0	0	0	0
BL11	0	0	0	0	1	1	1	1	0	4
BL12	0	0	0	0	0	0	1	1	0	2
BL13	0	0	0	0	1	1	1	1	0	4
BL14	1	1	1	1	1	1	0	0	0	6
BL15	1	1	1	1	0	0	0	0	0	4

BL16	1	1	1	1	1	1	0	0	0	6
BL17	1	1	1	1	0	0	0	0	0	4
BL18	0	0	0	0	0	0	1	1	0	2
BL19	0	0	0	0	1	1	1	1	0	4
BL20	0	0	0	0	0	0	0	0	0	0
BL21	0	0	0	0	1	1	1	1	0	4
BL22	1	1	1	1	1	1	1	1	0	8
BL23	1	1	1	1	0	0	0	0	0	4
BL24	0	0	0	0	0	0	1	1	0	2
BL25	0	0	0	0	1	1	1	1	0	4
BL26	1	1	1	1	1	1	0	0	0	6
BL27	1	1	1	1	0	0	0	0	0	4
BL28	1	1	1	1	1	1	1	1	0	8
BL29	1	1	1	1	0	0	0	0	0	4
BL30	0	0	0	0	0	0	0	0	0	0
BL31	0	0	0	0	1	1	1	1	0	4
# of 1s	16	16	16	16	16	16	16	16		

Notes 1: Simplified pattern; same data pattern was applied to DQ[4], DQ[5], DQ[6], and DQ[7] to reduce complexity for IDD4W pattern programming.

Data Pattern for IDD4R(DBI off) for BL=16

DBI Off Case										
	DQ7	DQ6	DQ5	DQ4	DQ3	DQ2	DQ1	DQ0	DBI	# of 1s
BL0	1	1	1	1	1	1	1	1	0	8
BL1	1	1	1	1	0	0	0	0	0	4
BL2	0	0	0	0	0	0	0	0	0	0
BL3	0	0	0	0	1	1	1	1	0	4
BL4	0	0	0	0	0	0	1	1	0	2
BL5	0	0	0	0	1	1	1	1	0	4
BL6	1	1	1	1	1	1	0	0	0	6
BL7	1	1	1	1	0	0	0	0	0	4
BL8	1	1	1	1	1	1	1	1	0	8
BL9	1	1	1	1	0	0	0	0	0	4
BL10	0	0	0	0	0	0	0	0	0	0
BL11	0	0	0	0	1	1	1	1	0	4
BL12	0	0	0	0	0	0	1	1	0	2
BL13	0	0	0	0	1	1	1	1	0	4
BL14	1	1	1	1	1	1	0	0	0	6
BL15	1	1	1	1	0	0	0	0	0	4
BL16	1	1	1	1	1	1	1	1	0	8
BL17	1	1	1	1	0	0	0	0	0	4
BL18	0	0	0	0	0	0	0	0	0	0
BL19	0	0	0	0	1	1	1	1	0	4
BL20	1	1	1	1	1	1	0	0	0	6
BL21	1	1	1	1	0	0	0	0	0	4

BL22	0	0	0	0	0	0	1	1	0	2
BL23	0	0	0	0	1	1	1	1	0	4
BL24	0	0	0	0	0	0	0	0	0	0
BL25	0	0	0	0	1	1	1	1	0	4
BL26	1	1	1	1	1	1	1	1	0	8
BL27	1	1	1	1	0	0	0	0	0	4
BL28	0	0	0	0	0	0	1	1	0	2
BL29	0	0	0	0	1	1	1	1	0	4
BL30	1	1	1	1	1	1	0	0	0	6
BL31	1	1	1	1	0	0	0	0	0	4
# of 1s	16	16	16	16	16	16	16	16		

Notes 1: Simplified pattern; same data pattern was applied to DQ[4], DQ[5], DQ[6], and DQ[7] to reduce complexity for IDD4W pattern programming.

Data Pattern for IDD4W(DBI On) for BL=16

DBI On Case										
	DQ[7]	DQ[6]	DQ[5]	DQ[4]	DQ[3]	DQ[2]	DQ[1]	DQ[0]	DBI	# of 1s
BL0	0	0	0	0	0	0	0	0	1	1
BL1	1	1	1	1	0	0	0	0	0	4
BL2	0	0	0	0	0	0	0	0	0	0
BL3	0	0	0	0	1	1	1	1	0	4
BL4	0	0	0	0	0	0	1	1	0	2
BL5	0	0	0	0	1	1	1	1	0	4
BL6	0	0	0	0	0	0	1	1	1	3
BL7	1	1	1	1	0	0	0	0	0	4
BL8	0	0	0	0	0	0	0	0	1	1
BL9	1	1	1	1	0	0	0	0	0	4
BL10	0	0	0	0	0	0	0	0	0	0
BL11	0	0	0	0	1	1	1	1	0	4
BL12	0	0	0	0	0	0	1	1	0	2
BL13	0	0	0	0	1	1	1	1	0	4
BL14	0	0	0	0	0	0	1	1	1	3
BL15	1	1	1	1	0	0	0	0	0	4
BL16	0	0	0	0	0	0	1	1	1	3
BL17	1	1	1	1	0	0	0	0	0	4
BL18	0	0	0	0	0	0	1	1	0	2
BL19	0	0	0	0	1	1	1	1	0	4
BL20	0	0	0	0	0	0	0	0	0	0
BL21	0	0	0	0	1	1	1	1	0	4
BL22	0	0	0	0	0	0	0	0	1	1
BL23	1	1	1	1	0	0	0	0	0	4
BL24	0	0	0	0	0	0	1	1	0	2
BL25	0	0	0	0	1	1	1	1	0	4
BL26	0	0	0	0	0	0	1	1	1	3
BL27	1	1	1	1	0	0	0	0	0	4
BL28	0	0	0	0	0	0	0	0	1	1
BL29	1	1	1	1	0	0	0	0	0	4
BL30	0	0	0	0	0	0	0	0	0	0
BL31	0	0	0	0	1	1	1	1	0	4
# of 1s	8	8	8	8	8	8	16	16	8	

Notes 1: DBI enabled burst: BL0, BL6, BL8, BL14, BL16, BL22, BL26, and BL28.

Data Pattern for IDD4R(DBI On) for BL=16

DBI On Case										
	DQ[7]	DQ[6]	DQ[5]	DQ[4]	DQ[3]	DQ[2]	DQ[1]	DQ[0]	DBI	# of 1s
BL0	0	0	0	0	0	0	0	0	1	1
BL1	1	1	1	1	0	0	0	0	0	4
BL2	0	0	0	0	0	0	0	0	0	0
BL3	0	0	0	0	1	1	1	1	0	4
BL4	0	0	0	0	0	0	1	1	0	2
BL5	0	0	0	0	1	1	1	1	0	4
BL6	0	0	0	0	0	0	1	1	1	3
BL7	1	1	1	1	0	0	0	0	0	4
BL8	0	0	0	0	0	0	0	0	1	1
BL9	1	1	1	1	0	0	0	0	0	4
BL10	0	0	0	0	0	0	0	0	0	0
BL11	0	0	0	0	1	1	1	1	0	4
BL12	0	0	0	0	0	0	1	1	0	2
BL13	0	0	0	0	1	1	1	1	0	4
BL14	0	0	0	0	0	0	1	1	1	3
BL15	1	1	1	1	0	0	0	0	0	4
BL16	0	0	0	0	0	0	0	0	1	1
BL17	1	1	1	1	0	0	0	0	0	4
BL18	0	0	0	0	0	0	0	0	0	0
BL19	0	0	0	0	1	1	1	1	0	4
BL20	0	0	0	0	0	0	1	1	1	3
BL21	1	1	1	1	0	0	0	0	0	4
BL22	0	0	0	0	0	0	1	1	0	2
BL23	0	0	0	0	1	1	1	1	0	4
BL24	0	0	0	0	0	0	0	0	0	0
BL25	0	0	0	0	1	1	1	1	0	4
BL26	0	0	0	0	0	0	0	0	1	1
BL27	1	1	1	1	0	0	0	0	0	4
BL28	0	0	0	0	0	0	1	1	0	2
BL29	0	0	0	0	1	1	1	1	0	4
BL30	0	0	0	0	0	0	1	1	1	3
BL31	1	1	1	1	0	0	0	0	0	4
# of 1s	8	8	8	8	8	8	16	16	8	

Notes 1: DBI enabled burst: BL0, BL6, BL8, BL14, BL20, BL26, and BL30.

CA Pattern for IDD4R for BL = 32

Clock Cycle Number	CKE	CS	Command	CA0	CA1	CA2	CA3	CA4	CA5
N	HIGH	HIGH	READ-1	L	H	L	L	L	L
N+1	HIGH	LOW		L	H	L	L	L	L
N+2	HIGH	HIGH	CAS-2	L	H	L	L	H	L
N+3	HIGH	LOW		L	L	L	L	L	L
N+4	HIGH	LOW	DES	L	L	L	L	L	L
N+5	HIGH	LOW	DES	L	L	L	L	L	L
N+6	HIGH	LOW	DES	L	L	L	L	L	L
N+7	HIGH	LOW	DES	L	L	L	L	L	L
N+8	HIGH	LOW	DES	L	L	L	L	L	L
N+9	HIGH	LOW	DES	L	L	L	L	L	L
N+10	HIGH	LOW	DES	L	L	L	L	L	L
N+11	HIGH	LOW	DES	L	L	L	L	L	L
N+12	HIGH	LOW	DES	L	L	L	L	L	L
N+13	HIGH	LOW	DES	L	L	L	L	L	L
N+14	HIGH	LOW	DES	L	L	L	L	L	L
N+15	HIGH	LOW	DES	L	L	L	L	L	L
N+16	HIGH	HIGH	READ-1	L	H	L	L	L	L
N+17	HIGH	LOW		L	H	L	L	H	L
N+18	HIGH	HIGH	CAS-2	L	H	L	L	H	H
N+19	HIGH	LOW		H	H	L	H	H	H
N+20	HIGH	LOW	DES	L	L	L	L	L	L
N+21	HIGH	LOW	DES	L	L	L	L	L	L
N+22	HIGH	LOW	DES	L	L	L	L	L	L
N+23	HIGH	LOW	DES	L	L	L	L	L	L
N+24	HIGH	LOW	DES	L	L	L	L	L	L
N+25	HIGH	LOW	DES	L	L	L	L	L	L
N+26	HIGH	LOW	DES	L	L	L	L	L	L
N+27	HIGH	LOW	DES	L	L	L	L	L	L
N+28	HIGH	LOW	DES	L	L	L	L	L	L
N+29	HIGH	LOW	DES	L	L	L	L	L	L
N+30	HIGH	LOW	DES	L	L	L	L	L	L
N+31	HIGH	LOW	DES	L	L	L	L	L	L

Notes 1: BA[2:0] = 010, C[9:5] = 00000 or 11111, Burst order C[4:2] = 000 or 111.

CA Pattern for IDD4W for BL = 32

Clock Cycle Number	CKE	CS	Command	CA0	CA1	CA2	CA3	CA4	CA5
N	HIGH	HIGH	WRITE-1	L	L	H	L	L	L
N+1	HIGH	LOW		L	H	L	L	L	L
N+2	HIGH	HIGH	CAS-2	L	H	L	L	H	L
N+3	HIGH	LOW		L	L	L	L	L	L
N+4	HIGH	LOW	DES	L	L	L	L	L	L
N+5	HIGH	LOW	DES	L	L	L	L	L	L
N+6	HIGH	LOW	DES	L	L	L	L	L	L
N+7	HIGH	LOW	DES	L	L	L	L	L	L
N+8	HIGH	LOW	DES	L	L	L	L	L	L
N+9	HIGH	LOW	DES	L	L	L	L	L	L
N+10	HIGH	LOW	DES	L	L	L	L	L	L
N+11	HIGH	LOW	DES	L	L	L	L	L	L
N+12	HIGH	LOW	DES	L	L	L	L	L	L
N+13	HIGH	LOW	DES	L	L	L	L	L	L
N+14	HIGH	LOW	DES	L	L	L	L	L	L
N+15	HIGH	LOW	DES	L	L	L	L	L	L
N+16	HIGH	HIGH	WRITE-1	L	L	H	L	L	L
N+17	HIGH	LOW		L	H	L	L	H	L
N+18	HIGH	HIGH	CAS-2	L	H	L	L	H	H
N+19	HIGH	LOW		L	L	L	H	H	H
N+20	HIGH	LOW	DES	L	L	L	L	L	L
N+21	HIGH	LOW	DES	L	L	L	L	L	L
N+22	HIGH	LOW	DES	L	L	L	L	L	L
N+23	HIGH	LOW	DES	L	L	L	L	L	L
N+24	HIGH	LOW	DES	L	L	L	L	L	L
N+25	HIGH	LOW	DES	L	L	L	L	L	L
N+26	HIGH	LOW	DES	L	L	L	L	L	L
N+27	HIGH	LOW	DES	L	L	L	L	L	L
N+28	HIGH	LOW	DES	L	L	L	L	L	L
N+29	HIGH	LOW	DES	L	L	L	L	L	L
N+30	HIGH	LOW	DES	L	L	L	L	L	L
N+31	HIGH	LOW	DES	L	L	L	L	L	L

Notes 1: BA[2:0] = 010, C[9:5] = 00000 or 11111.

Data Pattern for IDD4W (DBI Off) for BL = 32

DBI Off Case										
	DQ[7]	DQ[6]	DQ[5]	DQ[4]	DQ[3]	DQ[2]	DQ[1]	DQ[0]	DBI	# of 1s
BL0	1	1	1	1	1	1	1	1	0	8
BL1	1	1	1	1	0	0	0	0	0	4
BL2	0	0	0	0	0	0	0	0	0	0
BL3	0	0	0	0	1	1	1	1	0	4
BL4	0	0	0	0	0	0	1	1	0	2
BL5	0	0	0	0	1	1	1	1	0	4
BL6	1	1	1	1	1	1	0	0	0	6
BL7	1	1	1	1	0	0	0	0	0	4
BL8	1	1	1	1	1	1	1	1	0	8
BL9	1	1	1	1	0	0	0	0	0	4
BL10	0	0	0	0	0	0	0	0	0	0
BL11	0	0	0	0	1	1	1	1	0	4
BL12	0	0	0	0	0	0	1	1	0	2
BL13	0	0	0	0	1	1	1	1	0	4
BL14	1	1	1	1	1	1	0	0	0	6
BL15	1	1	1	1	0	0	0	0	0	4
BL16	1	1	1	1	1	1	0	0	0	6
BL17	1	1	1	1	0	0	0	0	0	4
BL18	0	0	0	0	0	0	1	1	0	2
BL19	0	0	0	0	1	1	1	1	0	4
BL20	0	0	0	0	0	0	0	0	0	0
BL21	0	0	0	0	1	1	1	1	0	4
BL22	1	1	1	1	1	1	1	1	0	8
BL23	1	1	1	1	0	0	0	0	0	4
BL24	0	0	0	0	0	0	1	1	0	2
BL25	0	0	0	0	1	1	1	1	0	4
BL26	1	1	1	1	1	1	0	0	0	6
BL27	1	1	1	1	0	0	0	0	0	4
BL28	1	1	1	1	1	1	1	1	0	8
BL29	1	1	1	1	0	0	0	0	0	4
BL30	0	0	0	0	0	0	0	0	0	0
BL31	0	0	0	0	1	1	1	1	0	4
BL32	1	1	1	1	1	1	1	1	0	8
BL33	1	1	1	1	0	0	0	0	0	4
BL34	0	0	0	0	0	0	0	0	0	0
BL35	0	0	0	0	1	1	1	1	0	4
BL36	0	0	0	0	0	0	1	1	0	2

Data Pattern for IDD4W (DBI Off) for BL = 32(continue)

DBI Off Case										
	DQ[7]	DQ[6]	DQ[5]	DQ[4]	DQ[3]	DQ[2]	DQ[1]	DQ[0]	DBI	# of 1s
BL37	0	0	0	0	1	1	1	1	0	4
BL38	1	1	1	1	1	1	0	0	0	6
BL39	1	1	1	1	0	0	0	0	0	4
BL40	1	1	1	1	1	1	1	1	0	8
BL41	1	1	1	1	0	0	0	0	0	4
BL42	0	0	0	0	0	0	0	0	0	0
BL43	0	0	0	0	1	1	1	1	0	4
BL44	0	0	0	0	0	0	1	1	0	2
BL45	0	0	0	0	1	1	1	1	0	4
BL46	1	1	1	1	1	1	0	0	0	6
BL47	1	1	1	1	0	0	0	0	0	4
BL48	1	1	1	1	1	1	0	0	0	6
BL49	1	1	1	1	0	0	0	0	0	4
BL50	0	0	0	0	0	0	1	1	0	2
BL51	0	0	0	0	1	1	1	1	0	4
BL52	0	0	0	0	0	0	0	0	0	0
BL53	0	0	0	0	1	1	1	1	0	4
BL54	1	1	1	1	1	1	1	1	0	8
BL55	1	1	1	1	0	0	0	0	0	4
BL56	0	0	0	0	0	0	1	1	0	2
BL57	0	0	0	0	1	1	1	1	0	4
BL58	1	1	1	1	1	1	0	0	0	6
BL59	1	1	1	1	0	0	0	0	0	4
BL60	1	1	1	1	1	1	1	1	0	8
BL61	1	1	1	1	0	0	0	0	0	4
BL62	0	0	0	0	0	0	0	0	0	0
BL63	0	0	0	0	1	1	1	1	0	4
# of 1s	32	32	32	32	32	32	32	32		

Notes 1: Simplified pattern; same data pattern was applied to DQ[4], DQ[5], DQ[6], and DQ[7] to reduce complexity for IDD4W pattern programming

Data Pattern for IDD4R (DBI Off) for BL = 32

DBI Off Case										
	DQ[7]	DQ[6]	DQ[5]	DQ[4]	DQ[3]	DQ[2]	DQ[1]	DQ[0]	DBI	# of 1s
BL0	1	1	1	1	1	1	1	1	0	8
BL1	1	1	1	1	0	0	0	0	0	4

Data Pattern for IDD4R (DBI Off) for BL = 32(Continue)

DBI Off Case										
	DQ[7]	DQ[6]	DQ[5]	DQ[4]	DQ[3]	DQ[2]	DQ[1]	DQ[0]	DBI	# of 1s
BL2	0	0	0	0	0	0	0	0	0	0
BL3	0	0	0	0	1	1	1	1	0	4
BL4	0	0	0	0	0	0	1	1	0	2
BL5	0	0	0	0	1	1	1	1	0	4
BL6	1	1	1	1	1	1	0	0	0	6
BL7	1	1	1	1	0	0	0	0	0	4
BL8	1	1	1	1	1	1	1	1	0	8
BL9	1	1	1	1	0	0	0	0	0	4
BL10	0	0	0	0	0	0	0	0	0	0
BL11	0	0	0	0	1	1	1	1	0	4
BL12	0	0	0	0	0	0	1	1	0	2
BL13	0	0	0	0	1	1	1	1	0	4
BL14	1	1	1	1	1	1	0	0	0	6
BL15	1	1	1	1	0	0	0	0	0	4
BL16	1	1	1	1	1	1	0	0	0	6
BL17	1	1	1	1	0	0	0	0	0	4
BL18	0	0	0	0	0	0	1	1	0	2
BL19	0	0	0	0	1	1	1	1	0	4
BL20	0	0	0	0	0	0	0	0	0	0
BL21	0	0	0	0	1	1	1	1	0	4
BL22	1	1	1	1	1	1	1	1	0	8
BL23	1	1	1	1	0	0	0	0	0	4
BL24	0	0	0	0	0	0	1	1	0	2
BL25	0	0	0	0	1	1	1	1	0	4
BL26	1	1	1	1	1	1	0	0	0	6
BL27	1	1	1	1	0	0	0	0	0	4
BL28	1	1	1	1	1	1	1	1	0	8
BL29	1	1	1	1	0	0	0	0	0	4
BL30	0	0	0	0	0	0	0	0	0	0
BL31	0	0	0	0	1	1	1	1	0	4
BL32	0	0	0	0	0	0	1	1	0	2
BL33	0	0	0	0	1	1	1	1	0	4
BL34	1	1	1	1	1	1	0	0	0	6
BL35	1	1	1	1	0	0	0	0	0	4
BL36	1	1	1	1	1	1	1	1	0	8
BL37	1	1	1	1	0	0	0	0	0	4
BL38	0	0	0	0	0	0	0	0	0	0

Data Pattern for IDD4R (DBI Off) for BL = 32(Continue)

DBI Off Case										
	DQ[7]	DQ[6]	DQ[5]	DQ[4]	DQ[3]	DQ[2]	DQ[1]	DQ[0]	DBI	# of 1s
BL39	0	0	0	0	1	1	1	1	0	4
BL40	0	0	0	0	0	0	1	1	0	2
BL41	0	0	0	0	1	1	1	1	0	4
BL42	1	1	1	1	1	1	0	0	0	6
BL43	1	1	1	1	0	0	0	0	0	4
BL44	1	1	1	1	1	1	1	1	0	8
BL45	1	1	1	1	0	0	0	0	0	4
BL46	0	0	0	0	0	0	0	0	0	0
BL47	0	0	0	0	1	1	1	1	0	4
BL48	1	1	1	1	1	1	1	1	0	8
BL49	1	1	1	1	0	0	0	0	0	4
BL50	0	0	0	0	0	0	0	0	0	0
BL51	0	0	0	0	1	1	1	1	0	4
BL52	1	1	1	1	1	1	0	0	0	6
BL53	1	1	1	1	0	0	0	0	0	4
BL54	0	0	0	0	0	0	1	1	0	2
BL55	0	0	0	0	1	1	1	1	0	4
BL56	0	0	0	0	0	0	0	0	0	0
BL57	0	0	0	0	1	1	1	1	0	4
BL58	1	1	1	1	1	1	1	1	0	8
BL59	1	1	1	1	0	0	0	0	0	4
BL60	0	0	0	0	0	0	1	1	0	2
BL61	0	0	0	0	1	1	1	1	0	4
BL62	1	1	1	1	1	1	0	0	0	6
BL63	1	1	1	1	0	0	0	0	0	4
# of 1s	32	32	32	32	32	32	32	32		

Notes 1: Simplified pattern; same data pattern was applied to DQ[4], DQ[5], DQ[6], and DQ[7] to reduce complexity for IDD4W/R pattern programming.

Data Pattern for IDD4W (DBI On) for BL = 32

DBI On Case										
	DQ[7]	DQ[6]	DQ[5]	DQ[4]	DQ[3]	DQ[2]	DQ[1]	DQ[0]	DBI	# of 1s
BL0	0	0	0	0	0	0	0	0	1	1
BL1	1	1	1	1	0	0	0	0	0	4
BL2	0	0	0	0	0	0	0	0	0	0
BL3	0	0	0	0	1	1	1	1	0	4

Data Pattern for IDD4W (DBI On) for BL = 32(Continue)

DBI On Case										
	DQ[7]	DQ[6]	DQ[5]	DQ[4]	DQ[3]	DQ[2]	DQ[1]	DQ[0]	DBI	# of 1s
BL4	0	0	0	0	0	0	1	1	0	2
BL5	0	0	0	0	1	1	1	1	0	4
BL6	0	0	0	0	0	0	1	1	1	3
BL7	1	1	1	1	0	0	0	0	0	4
BL8	0	0	0	0	0	0	0	0	1	1
BL9	1	1	1	1	0	0	0	0	0	4
BL10	0	0	0	0	0	0	0	0	0	0
BL11	0	0	0	0	1	1	1	1	0	4
BL12	0	0	0	0	0	0	1	1	0	2
BL13	0	0	0	0	1	1	1	1	0	4
BL14	0	0	0	0	0	0	1	1	1	3
BL15	1	1	1	1	0	0	0	0	0	4
BL16	0	0	0	0	0	0	1	1	1	3
BL17	1	1	1	1	0	0	0	0	0	4
BL18	0	0	0	0	0	0	1	1	0	2
BL19	0	0	0	0	1	1	1	1	0	4
BL20	0	0	0	0	0	0	0	0	0	0
BL21	0	0	0	0	1	1	1	1	0	4
BL22	0	0	0	0	0	0	0	0	1	1
BL23	1	1	1	1	0	0	0	0	0	4
BL24	0	0	0	0	0	0	1	1	0	2
BL25	0	0	0	0	1	1	1	1	0	4
BL26	0	0	0	0	0	0	1	1	1	3
BL27	1	1	1	1	0	0	0	0	0	4
BL28	0	0	0	0	0	0	0	0	1	1
BL29	1	1	1	1	0	0	0	0	0	4
BL30	0	0	0	0	0	0	0	0	0	0
BL31	0	0	0	0	1	1	1	1	0	4
BL32	0	0	0	0	0	0	0	0	1	1
BL33	1	1	1	1	0	0	0	0	0	4
BL34	0	0	0	0	0	0	0	0	0	0
BL35	0	0	0	0	1	1	1	1	0	4
BL36	0	0	0	0	0	0	1	1	0	2
BL37	0	0	0	0	1	1	1	1	0	4
BL38	0	0	0	0	0	0	1	1	1	3
BL39	1	1	1	1	0	0	0	0	0	4
BL40	0	0	0	0	0	0	0	0	1	1

Data Pattern for IDD4W (DBI On) for BL = 32(Continue)

DBI On Case										
	DQ[7]	DQ[6]	DQ[5]	DQ[4]	DQ[3]	DQ[2]	DQ[1]	DQ[0]	DBI	# of 1s
BL41	1	1	1	1	0	0	0	0	0	4
BL42	0	0	0	0	0	0	0	0	0	0
BL43	0	0	0	0	1	1	1	1	0	4
BL44	0	0	0	0	0	0	1	1	0	2
BL45	0	0	0	0	1	1	1	1	0	4
BL46	0	0	0	0	0	0	1	1	1	3
BL47	1	1	1	1	0	0	0	0	0	4
BL48	0	0	0	0	0	0	1	1	1	3
BL49	1	1	1	1	0	0	0	0	0	4
BL50	0	0	0	0	0	0	1	1	0	2
BL51	0	0	0	0	1	1	1	1	0	4
BL52	0	0	0	0	0	0	0	0	0	0
BL53	0	0	0	0	1	1	1	1	0	4
BL54	0	0	0	0	0	0	0	0	1	1
BL55	1	1	1	1	0	0	0	0	0	4
BL56	0	0	0	0	0	0	1	1	0	2
BL57	0	0	0	0	1	1	1	1	0	4
BL58	0	0	0	0	0	0	1	1	1	3
BL59	1	1	1	1	0	0	0	0	0	4
BL60	0	0	0	0	0	0	0	0	1	1
BL61	1	1	1	1	0	0	0	0	0	4
BL62	0	0	0	0	0	0	0	0	0	0
BL63	0	0	0	0	1	1	1	1	0	4
# of 1s	16	16	16	16	16	16	32	32	16	

Notes 1: DBI enabled burst: BL0, BL6, BL8, BL14, BL16, BL22, BL26, BL28, BL32, BL38, BL40, BL46, BL48, BL54, BL58, and BL60.

Data Pattern for IDD4R (DBI On) for BL = 32

DBI On Case										
	DQ[7]	DQ[6]	DQ[5]	DQ[4]	DQ[3]	DQ[2]	DQ[1]	DQ[0]	DBI	# of 1s
BL0	0	0	0	0	0	0	0	0	1	1
BL1	1	1	1	1	0	0	0	0	0	4
BL2	0	0	0	0	0	0	0	0	0	0
BL3	0	0	0	0	1	1	1	1	0	4
BL4	0	0	0	0	0	0	1	1	0	2
BL5	0	0	0	0	1	1	1	1	0	4

Data Pattern for IDD4R (DBI On) for BL = 32(continue)

DBI On Case										
	DQ[7]	DQ[6]	DQ[5]	DQ[4]	DQ[3]	DQ[2]	DQ[1]	DQ[0]	DBI	# of 1s
BL6	0	0	0	0	0	0	1	1	1	3
BL7	1	1	1	1	0	0	0	0	0	4
BL8	0	0	0	0	0	0	0	0	1	1
BL9	1	1	1	1	0	0	0	0	0	4
BL10	0	0	0	0	0	0	0	0	0	0
BL11	0	0	0	0	1	1	1	1	0	4
BL12	0	0	0	0	0	0	1	1	0	2
BL13	0	0	0	0	1	1	1	1	0	4
BL14	0	0	0	0	0	0	1	1	1	3
BL15	1	1	1	1	0	0	0	0	0	4
BL16	0	0	0	0	0	0	1	1	1	3
BL17	1	1	1	1	0	0	0	0	0	4
BL18	0	0	0	0	0	0	1	1	0	2
BL19	0	0	0	0	1	1	1	1	0	4
BL20	0	0	0	0	0	0	0	0	0	0
BL21	0	0	0	0	1	1	1	1	0	4
BL22	0	0	0	0	0	0	0	0	1	1
BL23	1	1	1	1	0	0	0	0	0	4
BL24	0	0	0	0	0	0	1	1	0	2
BL25	0	0	0	0	1	1	1	1	0	4
BL26	0	0	0	0	0	0	1	1	1	3
BL27	1	1	1	1	0	0	0	0	0	4
BL28	0	0	0	0	0	0	0	0	1	1
BL29	1	1	1	1	0	0	0	0	0	4
BL30	0	0	0	0	0	0	0	0	0	0
BL31	0	0	0	0	1	1	1	1	0	4
BL32	0	0	0	0	0	0	1	1	0	2
BL33	0	0	0	0	1	1	1	1	0	4
BL34	0	0	0	0	0	0	1	1	1	3
BL35	1	1	1	1	0	0	0	0	0	4
BL36	0	0	0	0	0	0	0	0	1	1
BL37	1	1	1	1	0	0	0	0	0	4
BL38	0	0	0	0	0	0	0	0	0	0
BL39	0	0	0	0	1	1	1	1	0	4
BL40	0	0	0	0	0	0	1	1	0	2
BL41	0	0	0	0	1	1	1	1	0	4
BL42	0	0	0	0	0	0	1	1	1	3

Data Pattern for IDD4R (DBI On) for BL = 32(continue)

DBI On Case										
	DQ[7]	DQ[6]	DQ[5]	DQ[4]	DQ[3]	DQ[2]	DQ[1]	DQ[0]	DBI	# of 1s
BL43	1	1	1	1	0	0	0	0	0	4
BL44	0	0	0	0	0	0	0	0	1	1
BL45	1	1	1	1	0	0	0	0	0	4
BL46	0	0	0	0	0	0	0	0	0	0
BL47	0	0	0	0	1	1	1	1	0	4
BL48	0	0	0	0	0	0	0	0	1	1
BL49	1	1	1	1	0	0	0	0	0	4
BL50	0	0	0	0	0	0	0	0	0	0
BL51	0	0	0	0	1	1	1	1	0	4
BL52	0	0	0	0	0	0	1	1	1	3
BL53	1	1	1	1	0	0	0	0	0	4
BL54	0	0	0	0	0	0	1	1	0	2
BL55	0	0	0	0	1	1	1	1	0	4
BL56	0	0	0	0	0	0	0	0	0	0
BL57	0	0	0	0	1	1	1	1	0	4
BL58	0	0	0	0	0	0	0	0	1	1
BL59	1	1	1	1	0	0	0	0	0	4
BL60	0	0	0	0	0	0	1	1	0	2
BL61	0	0	0	0	1	1	1	1	0	4
BL62	0	0	0	0	0	0	1	1	1	3
BL63	1	1	1	1	0	0	0	0	0	4
# of 1s	16	16	16	16	16	16	32	32	16	

Notes 1: DBI enabled burst: BL0, BL6, BL8, BL14, BL16, BL22, BL26, BL28, BL34, BL36, BL42, BL44, BL48, BL52, BL58, and BL62.

Power-up, initialization

To ensure proper functionality for power-up and reset initialization, default values for the MR settings are provided in the table below.

Item	Mode Register Setting	Default Setting	Description
FSP-OP/WR	MR13 OP[7:6]	00b	FSP-OP/WR[0] are enabled
WLS	MR2 OP[6]	0b	WRITE latency set A is selected
WL	MR2 OP[5:3]	000b	WL = 4
RL	MR2 OP[2:0]	000b	RL = 6, nRTP = 8
nWR	MR1 OP[6:4]	000b	nWR = 6
DBI-WR/RD	MR3 OP[7:6]	00b	Write and read DBI are disabled
CA ODT	MR11 OP[6:4]	000b	CA ODT is disabled
DQ ODT	MR11 OP[2:0]	000b	DQ ODT is disabled
V _{REF(CA)} setting	MR12 OP[6]	1b	V _{REF(CA)} range[1] is enabled
V _{REF(CA)} value	MR12 OP[5:0]	001101b	Range1: 27.2% of V _{DD2}
V _{REF(DQ)} setting	MR14 OP[6]	1b	V _{REF(DQ)} range[1] enabled
V _{REF(DQ)} value	MR14 OP[5:0]	001101b	Range1: 27.2% of V _{DDQ}

The following sequence must be used to power up the device. Unless specified otherwise, this procedure is mandatory. The power-up sequence of all channels must proceed simultaneously.

Voltage Ramp

1. While applying power (after T_a), RESET_n should be held LOW ($\leq 0.2 \times VDD2$), and all other inputs must be between $V_{IL,min}$ and $V_{IH,max}$. The device outputs remain at High-Z while RESET_n is held LOW. Power supply voltage ramp requirements are provided in the table below. VDD1 must ramp at the same time or earlier than VDD2. VDD2 must ramp at the same time or earlier than VDDQ.

After	Applicable Conditions
Ta is reached	VDD1 must be greater than VDD2
	VDD2 must be greater than VDDQ - 200mV

Notes 1: T_a is the point when any power supply first reaches 300mV.

Notes 2: Noted conditions apply between T_a and power-down (controlled or uncontrolled).

Notes 3: T_b is the point at which all supply and reference voltages are within their defined operating ranges.

Notes 4: Power ramp duration t_{INIT0} ($T_b - T_a$) must not exceed 20ms.

Notes 5: The voltage difference between any VSS and VSSQ must not exceed 100mV

2. Following completion of the of the voltage ramp (T_b), RESET_n must be held LOW for t_{INIT1} . DQ, DMI, DQS_t, and DQS_c voltage levels must be between VSSQ and VDDQ during voltage ramp to avoid latch-up. CK_t and CK_c, CS, and CA input levels must be between VSS and VDD2 during voltage ramp to avoid latch-up.

3. Beginning at T_b , RESET_n must remain LOW for at least t_{INIT1} (T_c), after which RESET_n can be de-asserted to HIGH (T_c). At least 10ns before CKE de-assertion, CKE is required to be set LOW. All other input signals are "Don't Care."

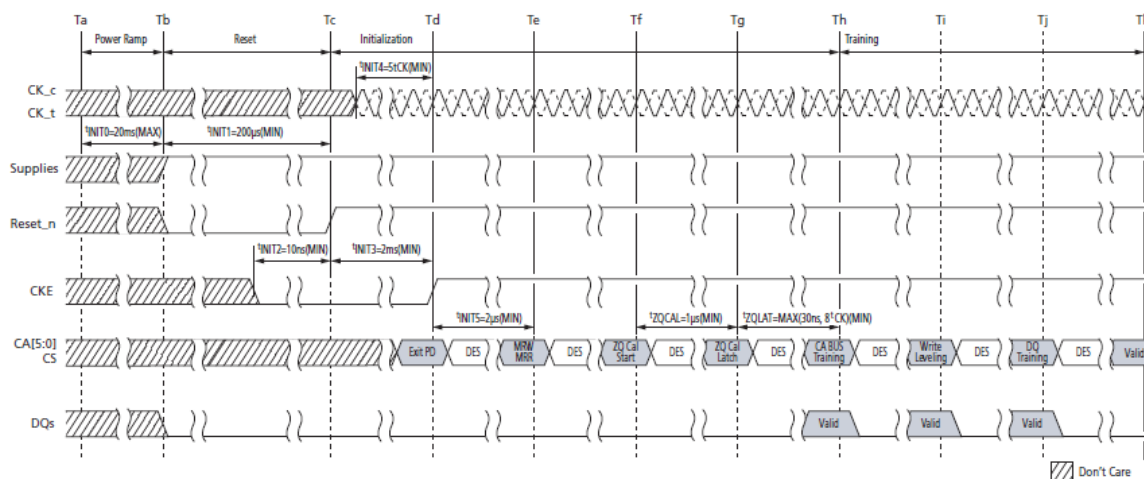

Notes 1: Training is optional and may be done at the system designer's discretion. The order of training may be different than what is shown here.

- After RESET_n is de-asserted (T_c), wait at least t_{INIT3} before activating CKE. CK_t, CK_c must be started and stabilized for t_{INIT4} before CKE goes active (T_d). CS must remain LOW when the controller activates CKE.
- After CKE is set to HIGH, wait a minimum of t_{INIT5} to issue any MRR or MRW commands (T_e). For MRR and MRW commands, the clock frequency must be within the range defined for t_{CKb} . Some AC parameters (for example, t_{DQSCK}) could have relaxed timings (such as t_{DQSCKb}) before the system is appropriately configured.
- After completing all MRW commands to set the pull-up, pull-down, and Rx termination values, the controller can issue the ZQCAL START command to the memory (T_f). This command is used to calibrate the VOH level and the output impedance over process, voltage, and temperature. In systems where more than one device share one external ZQ resistor, the controller must not overlap the ZQ calibration sequence of each device. The ZQ calibration sequence is completed after t_{ZQCAL} (T_g). The ZQCAL LATCH command must be issued to update the DQ drivers and DQ + CA ODT to the calibrated values.

7. After tZQLAT is satisfied (Th), the command bus (internal VREF(CA), CS, and CA) should be trained for high-speed operation by issuing an MRW command (command bus training mode). This command is used to calibrate the device's internal VREF and align CS/CA with CK for high-speed operation. The device will power-up with receivers configured for low-speed operations and with VREF(CA) set to a default factory setting. Normal device operation at clock speeds higher than tCKb may not be possible until command bus training is complete. The command bus training MRW command uses the CA bus as inputs for the calibration data stream, and it outputs the results asynchronously on the DQ bus. See command bus training in the MRW section for information on how to enter/exit the training mode.
8. After command bus training, the controller must perform write leveling. Write leveling mode is enabled when MR2 OP[7] is HIGH(Ti). See the Write Leveling section for a detailed description of the write leveling entry and exit sequence. In write leveling mode, the controller adjusts write DQS timing to the point where the device recognizes the start of write DQ data burst with desired WRITE latency.
9. After write leveling, the DQ bus (internal VREF(DQ), DQS, and DQ) should be trained for high-speed operation using the MPC TRAINING commands and by issuing MRW commands to adjust VREF(DQ). The device will power-up with receivers configured for low-speed operations and with VREF(DQ) set to a default factory setting. Normal device operation at clock speeds higher than tCKb should not be attempted until DQ bus training is complete. The MPC[READ DQ CALIBRATION] command is used together with MPC[READ-FIFO] or MPC[WRITE-FIFO] commands to train the DQ bus without disturbing the memory array contents.
10. At Tk, the device is ready for normal operation and is ready to accept any valid command. Any mode registers that have not previously been configured for normal operation should be written at this time.

Mode Registers

Mode Register Assignment and Definition

The table listed below shows the mode registers for LPDDR4 SDRAM. A Mode Register Read command is used to read a mode register. A Mode Register Write command is used to write a mode register.

Mode Register Assignments(continued)

MR#	OP[7]	OP[6]	OP[5]	OP[4]	OP[3]	OP[2]	OP[1]	OP[0]
0	CATR	RFU	Single Ended Mode	RZQI		RFU	Latency Mode	Refresh Mode
1	RPST	nWR (for AP)			RD-PRE	WR-PRE	BL	
2	WR Lev	WLS	WL			RL		
3	DBI-WR	DBI-RD	PDDS			PPRP	WR PST	PU-CAL
4	TUF	Thermal Offset		PPRE	SR Abort	Refresh Rate		
5	LPDDR4 Manufacturer ID							
6	Revision ID-1							
7	Revision ID-2							
8	IO Width		Density				Type	
9	Vendor Specific Test Register							
10	RFU							ZQ-Reset
11	Reserved	CA ODT			Reserved	DQ ODT		
12	RFU	VR-CA	VREF(CA)					
13	FSP-OP	FSP-WR	DMD	RRO	VRCG	VRO	RPT	CBT
14	RFU	VR(dq)	VREF(DQ)					
15	Lower-Byte Invert Register for Calibration							
16	PASR Bank Mask							
17	PASR Segment Mask							
18	DQS Oscillator Count - LSB							
19	DQS Oscillator Count - MSB							
20	Upper-Byte Invert Register for DQ Calibration							
21	RFU	Low Speed CA Buffer	RFU					
22	Reserved	ODTD-CA	ODTE-CS	ODTE-CK	SOC ODT			
23	DQS interval timer run time setting							
24	TRR Mode	TRR Mode BAn			Unlimited MAC	MAC Value		
25	PPR Resource							
26~29	RFU							
30	Reserved for testing – SDRAM will ignore							
31	RFU							
32	DQ Calibration Pattern "A" (default = 5A _H)							
33~38	RFU							
39	Reserved for testing – SDRAM will ignore							
40	DQ Calibration Pattern "B" (default = 3C _H)							
41~50	RFU							
51	RFU				Single Ended Clock	Single Ended WDQS	Single Ended RDQS	RFU

MR0 Device Feature 0 (MA[5:0] = 00h)

OP[7]	OP[6]	OP[5]	OP[4]	OP[3]	OP[2]	OP[1]	OP[0]
CATR	RFU	Single Ended Mode	RZQI		RFU	Latency Mode	Refresh Mode

Function	Type	Operand	Data	Notes
Refresh Mode	Read-only	OP[0]	0b: Both legacy and modified refresh mode supported (default) 1b: Only modified refresh mode supported	
Latency Mode		OP[1]	0b: Device supports normal latency 1b: Reserved	5
RZQI (Built-in Self-Test for RZQ)		OP[4:3]	00b: RZQ Self-Test not support. 01b: ZQ-pin may connect to VSSQ or float 10b: ZQ-pin may short to VDDQ 11b: ZQ-pin Self-Test completed, no error condition detected (ZQ-pin may not connect to VSSQ or float ,nor short to VDDQ)	1, 2, 3, 4
Single Ended Mode		OP[5]	1b: Supports for Single Ended Mode	6
CATR (CA Terminating Rank)		OP[7]	0b: CA for this rank is not terminated 1b: CA for this rank is terminated	7

Notes 1: RZQI MR value, if supported, will be valid after the following sequence:

- Completion of MPC[ZQCAL START] command to either channel
 - Completion of MPC[ZQCAL LATCH] command to either channel then tZQLAT is satisfied
- RZQI value will be lost after reset

Notes 2: If ZQ is connected to VSSQ to set default calibration, OP[4:3] must be set to 01b. If ZQ is not connected to VSSQ, either OP[4:3] = 01b or OP[4:3] = 10b might indicate a ZQ pin assembly error. It is recommended that the assembly error be corrected..

Notes 3: In the case of possible assembly error, the device will default to factory trim settings for RON, and will ignore ZQ CALIBRATION commands. In either case, the device may not function as intended.

Notes 4: If the ZQ pin self-test returns OP[4:3] = 11b, the device has detected a resistor connected to the ZQ pin. However, this result cannot be used to validate the ZQ resistor value or that the ZQ resistor meets the specified limits (that is, 240Ω ±1%).

Notes 5: Byte mode is not supported.

Notes 6: OP[5] set to 1b support for Single Ended Mode, Single Ended Write DQS, Read DQS and CK can be enabled in MR51.

Notes 7: CATR can either indicate the connection status of the ODTCA pad for the die or whether CA for the rank is terminated.

MR1 Device Feature 1 (MA[5:0] = 01h)

OP7	OP6	OP5	OP4	OP3	OP2	OP1	OP0
RD-PST	nWR (for AP)			RD-PRE	WR-PRE	BL	

MR1 Op-Code Bit Definitions

Feature	Type	OP	Definition	Notes
BL Burst length	Write-only	OP[1:0]	00b: BL = 16 sequential (default) 01b: BL = 32 sequential 10b: BL = 16 or 32 sequential (on-the-fly) 11b: Reserved	1
WR-PRE Write preamble length	Write-only	OP[2]	0b: Reserved 1b: WR preamble = $2 \times t_{CK}$	5, 6
RD-PRE Read preamble type	Write-only	OP[3]	0b: RD preamble = Static (default) 1b: RD preamble = Toggle	3, 5, 6

Feature	Type	OP	Definition	Notes
nWR Write-recovery for AUTO PRECHARGE command	Write-only	OP[6:4]	000b: nWR = 6 (default) 001b: nWR = 10 010b: nWR = 16 011b: nWR = 20 100b: nWR = 24 101b: nWR = 30 110b: nWR = 34 111b: nWR = 40	2, 5, 6
RD-PST Read postamble length	Write-only	OP[7]	0b: RD postamble = $0.5 \times t_{CK}$ (default) 1b: RD postamble = $1.5 \times t_{CK}$	4, 5, 6

Notes 1: Burst length on-the-fly can be set to either BL = 16 or BL = 32 by setting the BL bit in the command operands. See the Command Truth Table.

Notes 2: The programmed value of nWR is the number of clock cycles the device uses to determine the starting point of an internal precharge after a write burst with auto precharge (AP) enabled.

Notes 3: For READ operations, this bit must be set to select between a toggling preamble and a non-toggling preamble.

Notes 4: OP[7] provides an optional read postamble with an additional rising and falling edge of DQS_t. The optional postamble cycle is provided for the benefit of certain memory controllers.

Notes 5: There are two physical registers assigned to each bit of this MR parameter: designated set point 0 and set point 1. Only the registers for the set point determined by the state of the FSP-WR bit (MR13 OP[6]) will be written to with an MRW command to this MR address.

Notes 6: There are two physical registers assigned to each bit of this MR parameter: designated set point 0 and set point 1. The device will operate only according to the values stored in the registers for the active set point, that is, the set point determined by the state of the FSP-OP bit (MR13 OP[7]). The values in the registers for the inactive set point will be ignored by the device and may be changed without affecting device operation.

MR2 MR2 Device Feature (MA[5:0] = 02Ch)

OP7	OP6	OP5	OP4	OP3	OP2	OP1	OP0
WR Lev	WLS		WL			RL	

MR2 Op-Code Bit Definitions

Feature	Type	OP	Definition	Notes
RL READ latency	Write-only	OP[2:0]	RL and nRTP for DBI-RD disabled (MR3 OP[6] = 0b) 000b: RL = 6, nRTP = 8 (default) 001b: RL = 10, nRTP = 8 010b: RL = 14, nRTP = 8 011b: RL = 20, nRTP = 8 100b: RL = 24, nRTP = 10 101b: RL = 28, nRTP = 12 110b: RL = 32, nRTP = 14 111b: RL = 36, nRTP = 16 <hr/> RL and nRTP for DBI-RD enabled (MR3 OP[6] = 1b) 000b: RL = 6, nRTP = 8 001b: RL = 12, nRTP = 8 010b: RL = 16, nRTP = 8 011b: RL = 22, nRTP = 8 100b: RL = 28, nRTP = 10 101b: RL = 32, nRTP = 12 110b: RL = 36, nRTP = 14 111b: RL = 40, nRTP = 16	1, 3, 4
WL WRITE latency	Write-only	OP[5:3]	WL set A (MR2 OP[6] = 0b) 000b: WL = 4 (default) 001b: WL = 6 010b: WL = 8 011b: WL = 10 100b: WL = 12 101b: WL = 14 110b: WL = 16 111b: WL = 18 <hr/> WL set B (MR2 OP[6] = 1b) 000b: WL = 4 001b: WL = 8 010b: WL = 12 011b: WL = 18 100b: WL = 22 101b: WL = 26 110b: WL = 30 111b: WL = 34	1, 3, 4
WLS WRITE latency set	Write-only	OP[6]	0b: Use WL set A (default) 1b: Use WL set B	1, 3, 4
WR Lev Write leveling	Write-only	OP[7]	0b: Disable write leveling (default) 1b: Enable write leveling	2

Notes 1: See Latency Code Frequency Table for allowable Frequency Ranges for RL/WL/nWR/nRTP.

Notes 2: After an MRW command to set the write leveling enable bit (OP[7] = 1b), the device remains in the MRW state until another MRW command clears the bit (OP[7] = 0b). No other commands are allowed until the write leveling enable bit is cleared.

Notes 3: There are two physical registers assigned to each bit of this MR parameter: designated set point 0 and set point 1. Only the registers for the set point determined by the state of the FSP-WR bit (MR13 OP[6]) will be written to with an MRW command this MR address, or read from with an MRR command to this address.

Notes 4: There are two physical registers assigned to each bit of this MR parameter: designated set point 0 and set point 1. The device will operate only according to the values stored in the registers for the active set point, that is, the set point determined by the state of the FSP-OP bit (MR13 OP[7]). The values in the registers for the inactive set point will be ignored by the device and may be changed without affecting device operation.

Mode Register 14 (MA[5:0] = 0Eh)

OP[7]	OP[6]	OP[5]	OP[4]	OP[3]	OP[2]	OP[1]	OP[0]
RFU	VR _{DQ}	V _{REF(DQ)}					

MR14 Op-Code Bit Definition

Feature	Type	OP	Definition	Notes
V _{REF(DQ)} V _{REF(DQ)} setting	Read/ Write	OP[5:0]	000000b–110010b: See V _{REF} Settings table All others: Reserved	1–3, 5, 6
VR _{DQ} V _{REF(DQ)} range		OP[6]	0b: V _{REF(DQ)} range[0] enabled 1b: V _{REF(DQ)} range[1] enabled (default)	1, 2, 4–6

Notes 1: This register controls the VREF(DQ) levels for frequency set point[1:0]. Values from either VRDQ [vendor defined] or VRDQ [vendor defined] may be selected by setting OP[6] appropriately.

Notes 2: A read (MRR) to this register places the contents of OP[7:0] on DQ[7:0]. Any RFU bits and unused DQ will be set to 0.

Notes 3: write to OP[5:0] sets the internal VREF(DQ) level for FSP[0] when MR13 OP[6] = 0b, or sets FSP[1] when MR13 OP[6] = 1b. The time required for VREF(DQ) to reach the set level depends on the step size from the current level to the new level.

Notes 4: A write to OP[6] switches the device between two internal VREF(DQ) ranges. The range (range[0] or range[1]) must be selected when setting the VREF(DQ) register. The value, once set, will be retained until overwritten, or until the next power-on or reset event.

Notes 5: There are two physical registers assigned to each bit of this MR parameter, designated set point 0 and set point 1. Only the registers for the set point determined by the state of the FSP-WR bit (MR13 OP[6]) will be written to with an MRW command to this MR address, or read from with an MRR command to this address.

Notes 6: There are two physical registers assigned to each bit of this MR parameter, designated set point 0 and set point 1. The device will operate only according to the values stored in the registers for the active set point, for example, the set point determined by the state of the FSP-OP bit (MR13 OP[7]). The values in the registers for the inactive set point will be ignored by the device, and may be changed without affecting device operation.

MR22 Register Information (MA[5:0] = 16h)

OP[7]	OP[6]	OP[5]	OP[4]	OP[3]	OP[2]	OP[1]	OP[0]
RFU		ODTD-CA	ODTE-CS	ODTE-CK	SOC ODT		

MR22 Register Information

Function	Type	Operand	Data	Notes
SoC ODT (Controller ODT Value for VOH calibration)	Write-only	OP[2:0]	000_b : Disable (Default) 001_b : RZQ/1 010_b : RZQ/2 011_b : RZQ/3 100_b : RZQ/4 101_b : RZQ/5 110_b : RZQ/6 111_b : Reserved	1, 2, 3
ODTE-CK (CK ODT enabled for nonterminating rank)		OP[3]	0_b : ODT-CK Over-ride Disabled (Default) 1_b : ODT-CK Over-ride Enabled	2, 3, 4, 6, 8
ODTE-CS (CS ODT enable for nonterminating rank)		OP[4]	0_b : ODT-CS Over-ride Disabled (Default) 1_b : ODT-CS Over-ride Enabled	2, 3, 5, 6, 8
ODTD-CA (CA ODT termination disable)		OP[5]	0_b : ODT-CA Obeyes ODT_CA bond pad (default) 1_b : ODT-CA Disabled	2, 3, 6, 7, 8

Notes 1: All values are typical.

Notes 2: There are two physical registers assigned to each bit of this MR parameter: designated set point 0 and set point 1. Only the registers for the set point determined by the state of the FSP-WR bit (MR13 OP[6]) will be written to with an MRW command or read from with an MRR command to this address.

Notes 3: There are two physical registers assigned to each bit of this MR parameter: designated set point 0 and set point 1. The device will operate only according to the values stored in the registers for the active set point determined by the state of the FSP-OP bit (MR13 OP[7]). The values in the registers for the inactive set point will be ignored by the device and may be changed without affecting device operation.

Notes 4: When OP[3]=1, then the CK signals will be terminated to the value set by MR11-OP[6:4] regardless of the state of the ODT_CA bond pad. This overrides the ODT_CA bond pad for configurations where CA is shared by two or more DRAMs but CK is not, allowing CK to terminate on all DRAMs.

Notes 5: When OP[4]=1, then the CS signal will be terminated to the value set by MR11-OP[6:4] regardless of the state of the ODT_CA bond pad. This overrides the ODT_CA bond pad for configurations where CA is shared by two or more DRAMs but CS is not, allowing CS to terminate on all DRAMs.

Notes 6: For system configurations where the CK, CS, and CA signals are shared between packages, the package design should provide for the ODT_CA ball to be bonded on the system board outside of the memory package. This provides the necessary control of the ODT function for all die with shared Command Bus signals.

Notes 7: When OP[5]=0, CA[5:0] will terminate when the ODT_CA bond pad is HIGH and MR11-OP[6:4] is VALID, and disables termination when ODT_CA is LOW or MR11-OP[6:4] is disabled. When OP[5]=1, termination for CA[5:0] is disabled, regardless of the state of the ODT_CA bond pad or MR11-OP[6:4].

Notes 8: To ensure proper operation in a multi-rank configuration, when CA, CK or CS ODT is enabled via MR11 OP[6:4] and also via MR22 or ODT_CA pad setting, the rank providing ODT will continue to terminate the command bus in all DRAM states including Active Self Refresh, Self Refresh Power-down, Active Power-down and Precharge Power-down.

Package Description

200-ball FBGA 10x14.5mm

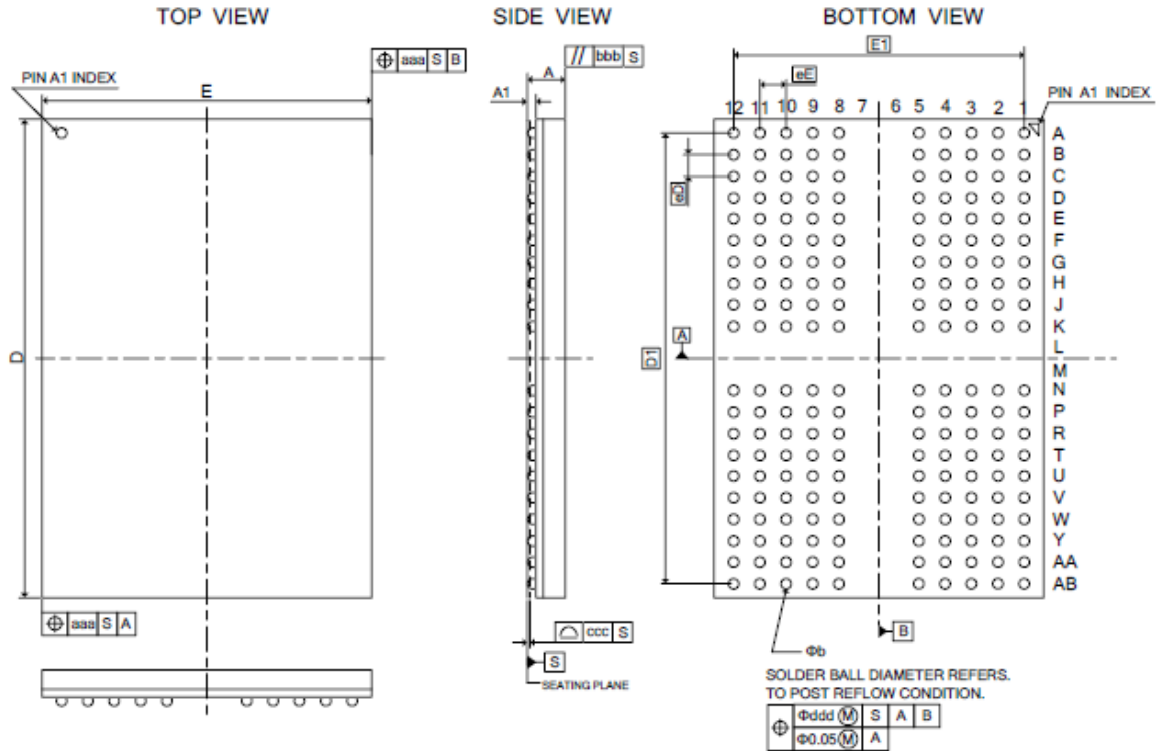

Controlling Dimension:
Millimeters

SYMBOL	DIMENSION (MM)			DIMENSION (Inch)		
	MIN.	NOM.	MAX.	MIN.	NOM.	MAX.
A	0.60	0.70	0.80	0.021	0.026	0.031
A1	0.177	0.227	0.277	0.007	0.009	0.011
b	0.313	0.363	0.413	0.012	0.014	0.016
D	14.40	14.50	14.60	0.566	0.570	0.574
E	9.90	10.00	10.10	0.389	0.393	0.397
D1	13.65 BSC.			0.537 BSC.		
E1	8.80 BSC.			0.346 BSC.		
eD	0.65 BSC.			0.025 BSC.		
eE	0.80 BSC.			0.031 BSC.		
aaa	0.15 BSC.			0.0059 BSC.		
bbb	---	---	0.10	---	---	0.0039
ccc	---	---	0.10	---	---	0.0039
ddd	---	---	0.15	---	---	0.0059

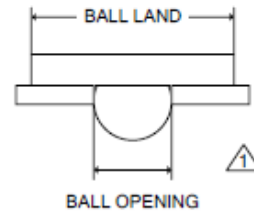

Note:
1. Ball land: 0.41mm, Ball opening: 0.35mm

Revision History

Revision No.	History	Draft Date	Editor	Remark
0.1	Initial Release.	May. 2023	Rico Yang	N/A
1.0	First SPEC. release.	Dec. 2023	Rico Yang	N/A